

Key: 6172

Town of SCITUATE - Fiscal Year 2024

10/18/2023 5:31 pm SEQ #: 5.874

LEGAL

LAND

DETACHED

BUILDING

CURRENT OWNER				PARCEL ID				LOCATION				
VALLELY JOHN & ALEXANDRA 76 COUNTRY WAY SCITUATE, MA 02066				48-2-54-A				76 COUNTRY WAY				
TRANSFER HISTORY				DOS	T	SALE PRICE	BK-PG (Cert)					
VALLELY JOHN & ALEXANDRA				06/28/2022	QS	700,000	(134086)					
HUTSON ERIC & COLLEEN				03/21/2018	QS	477,000	(126533)					
DRISCOLL RYAN A & CATHLEE				02/29/2012	QS	295,000	(117127)					
CD	T	AC/SF/UN	Ngh	Inf1	Inf2	ADJ BASE	SAF	Inf3	Lpi	VC	CREDIT AMT	ADJ VALUE
100	S	20,300	SC 1.00	100	1.00	396,000	1.84	100	1.00	R02	0.90	340,360

CLASS	CLASS%	DESCRIPTION			BN ID	BN	CARD	
1010	100	SINGLE FAMILY				1	1 of 1	
PMT NO	PMT DT	TY	DESC	AMOUNT	INSP	BY	1st	%
23-317	04/12/2023	3	ALTERATIONS	21,500	06/02/2023	NC	50	50
14-315	06/16/2014	4	DEMO	700	08/10/2015	SJ	100	100

TOTAL	20,300 SF	ZONING	FRNT	187	ASSESSED	CURRENT	PREVIOUS
Ngh	SCITUATE	NOTE			LAND	340,400	326,600
Inf1	FACTOR 100		BUILDING	311,200	257,600		
Inf2	PHY 100		DETACHED	1,200	1,100		
			OTHER	0	0		
TOTAL						652,800	585,300

TY	QUAL	COND	DIM/NOTE	YB	UNITS	ADJ PRICE	RCNLD
SHF	A	1.00	30 0.70	10 X 12	120	13.93	1,200

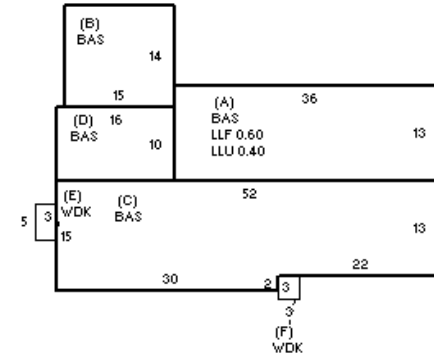

BUILDING	CD	ADJ	DESC	MEASURE	8/19/2019	JD
MODEL	1		RESIDENTIAL	LIST	8/19/2019	EST
STYLE	3	1.00	SPLIT LEVEL [100%]	REVIEW	8/2/2023	JD
QUALITY	A	1.00	AVERAGE [100%]			
FRAME	1	1.00	WOOD FRAME [100%]			

BLDG COMMENTS
MLS

YEAR BLT	1961	SIZE ADJ	1.000	ELEMENT	CD	DESCRIPTION	ADJ	S	BAT	T	DESCRIPTION	UNITS	YB	ADJ PRICE	RCN	TOTAL RCN	388,957			
NET AREA	1,855	DETAIL ADJ	1.030	FOUNDATION	4	CONT BSMT WALL	1.00	A	LLU	N	LOWER LEVEL UNF	187		60.01	11,222	CONDITION ELEM	CD			
\$NLA(RCN)	\$210	OVERALL	1.000	EXT COVER	1	WD SHINGLES	1.00	A	LLF	L	LOWER LEVEL FIN	281	1961	142.57	40,063	EXTERIOR	A			
				ROOF SHAPE	1	GABLE	1.00	B	BAS	L	BASE AREA	210	2023	206.70	43,407	INTERIOR	G			
				ROOF COVER	1	ASPH SHINGLES	1.00	+	BAS	L	BASE AREA	1,364	1961	206.70	281,942	KITCHEN	V			
				FLOOR COVER	34	COMB	1.00	+	WDK	N	WOOD DECK	24		38.42	922	BATHS	G			
				INT FINISH	1	PLASTER	1.00	F11	O	O	FPL 1S 1OP	1		7,281.00	7,281	HEAT	U			
				HEATING/COOLING	9	WARM/COOL AIR	1.03											ELECT	U	
				FUEL SOURCE	2	GAS	1.00											EFF.YR/AGE 2006 / 16		
																		COND	16	16 %
																		FUNC	4	UC
																		ECON	0	
																		DEPR	20	% GD 80
																		RCNLD	\$311,200	