

Key: 6262

Town of SCITUATE - Fiscal Year 2024

10/18/2023 5:31 pm SEQ #: 5.959

LEGAL

CURRENT OWNER		PARCEL ID		LOCATION	
RIVER CHASE APARTMENTS LP C/O DAN R LAKS 91 SIDNEY STREET, STE # 207 CAMBRIDGE, MA 02139		53-5-3-0		50 COUNTRY WAY	
TRANSFER HISTORY		DOS	T	SALE PRICE	BK-PG (Cert)
RIVER CHASE APARTMENTS LP		12/20/2021	QS	15,500,000	(133202)
GREENBUSH STATION LLC		01/29/2016	O	1,920,000	(123012)
FORD CHRISTOPHER TRUSTEE		02/12/1997	QS	310,000	(90987)

CLASS	CLASS%	DESCRIPTION		BN ID	BN	CARD	
0130	85	MULTI-USE RES			1	1 of 3	
PMT NO	PMT DT	TY	DESC	AMOUNT	INSP	BY	1st %
18-801	11/15/2018	1	NEW CONST		04/29/2019	JD	100 100
18-785	11/06/2018	3	ALTERATIONS	30,000	04/29/2019	JD	100 100
		2	ADDITIONS	10,000	04/29/2019	JD	100 100
		1	NEW CONST		05/21/2018	JD	100 95
17-771	12/05/2017	1	NEW CONST	1,800,000	05/11/2018	JD	100 75

LAND

CD	T	AC/SF/UN	Ngh	Inf1	Inf2	ADJ BASE	SAF	Inf3	Lpi	VC	CREDIT AMT	ADJ VALUE
112	U		32 C03	1.00	100 1.00	105,600	1.00	100 1.00	APG	1.50		3,379,200

TOTAL	1.405 Acres	ZONING	FRNT	50	ASSESSED	CURRENT	PREVIOUS
Ngh	3	NOTE combined w/ 53-5-3-B fy19	LAND	3,379,200	4,096,000		
Inf1	FACTOR 100		BUILDING	3,329,000	3,214,700		
Inf2	PHY 100		DETACHED	61,200	57,600		
			OTHER	6,462,100	7,203,100		
			TOTAL	13,231,500	14,571,400		

DETACHED

TY	QUAL	COND	DIM/NOTE	YB	UNITS	ADJ PRICE	RCNLD
PAV	G	1.20 50 0.50			30,000	4.08	61,200

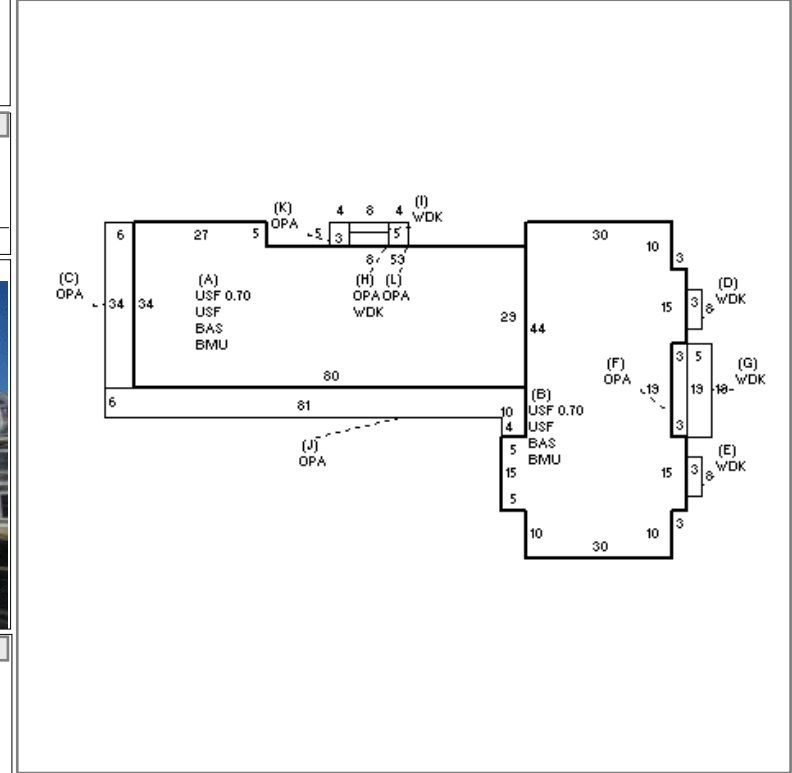

BUILDING

BUILDING	CD	ADJ	DESC	MEASURE	6/11/2018	JD
MODEL	5		CIM-5	LIST	6/11/2018	JD
STYLE	20	0.85	OFFICE BUILDING [39%]	REVIEW		
QUALITY	S	2.10	SUPERLATIVE [100%]			
FRAME	1	1.00	WOOD FRAME [100%]			

BLDG COMMENTS
Building A

G

YEAR BLT	2018	SIZE ADJ	1.000	ELEMENT	CD	DESCRIPTION	ADJ	S	BAT	T	DESCRIPTION	UNITS	YB	ADJ PRICE	RCN	TOTAL RCN	3,467,738
NET AREA	12,663	DETAIL ADJ	0.839	FOUNDATION	4	FLR & WALL	1.00	+	BMU	N	BSMT UNF	4,690		58.80	275,772	CONDITION ELEM	CD
\$NLA(RCN)	\$274	OVERALL	1.000	EXT. COVER	4	VINYL	1.00	A	BAS	L	BASE AREA	2,455	2018	242.48	595,278	EXTERIOR	A
				ROOF SHAPE	1	GABLE	1.00	A	USF	L	UP-STRY FIN	2,455	2018	242.48	595,278	INTERIOR	A
				ROOF COVER	1	ASPH/CMP SHIN	1.00	+	USF	L	UP-STRY FIN	3,283	2018	242.48	796,048	CDN/APP	A
				FLOOR COVER	6	OTHER	1.00	B	BAS	L	BASE AREA	2,235	2018	242.48	541,934		
				INT. FINISH	2	DRYWALL	1.00	B	USF	L	UP-STRY FIN	2,235	2018	242.48	541,934		
				HEATING/COOL	9	WARM/COOL AIR	1.00	+	OPA	N	OPEN PORCH	861		58.80	50,627		
				FUEL SOURCE	2	GAS	1.00	+	WDK	N	WOOD DECK	183		46.20	8,455		
									ELV	O	PASSGR. ELEV.	1		62,412.00	62,412		
																EFF.YR/AGE	2018 / 4
																COND	4 4 %
																FUNC	0
																ECON	0
																DEPR	4 % GD 96
																RCNLD	\$3,329,000

Key: 6262

Town of SCITUATE - Fiscal Year 2024

10/18/2023 5:31 pm SEQ #: 5.960

LEGAL

CURRENT OWNER		PARCEL ID		LOCATION	
RIVER CHASE APARTMENTS LP C/O DAN R LAKS 91 SIDNEY STREET, STE # 207 CAMBRIDGE, MA 02139		53-5-3-0		50 COUNTRY WAY	
TRANSFER HISTORY		DOS	T	SALE PRICE	BK-PG (Cert)

CLASS	CLASS%	DESCRIPTION			BN ID	BN	CARD
0130	85	MULTI-USE RES				2	2 of 3
PMT NO	PMT DT	TY	DESC	AMOUNT	INSP	BY	1st %

LAND

CD	T	AC/SF/UN	Ngh	Inf1	Inf2	ADJ BASE	SAF	Inf3	Lpi	VC	CREDIT AMT	ADJ VALUE
----	---	----------	-----	------	------	----------	-----	------	-----	----	------------	-----------

TOTAL	ZONING	FRNT	ASSESSED	CURRENT	PREVIOUS
Ngh	NOTE		LAND	4,466,700	
Inf1		BUILDING			
Inf2		DETACHED			
			OTHER		
			TOTAL		

DETACHED

TY	QUAL	COND	DIM/NOTE	YB	UNITS	ADJ PRICE	RCNLD	PHOTO
								01/20/2022



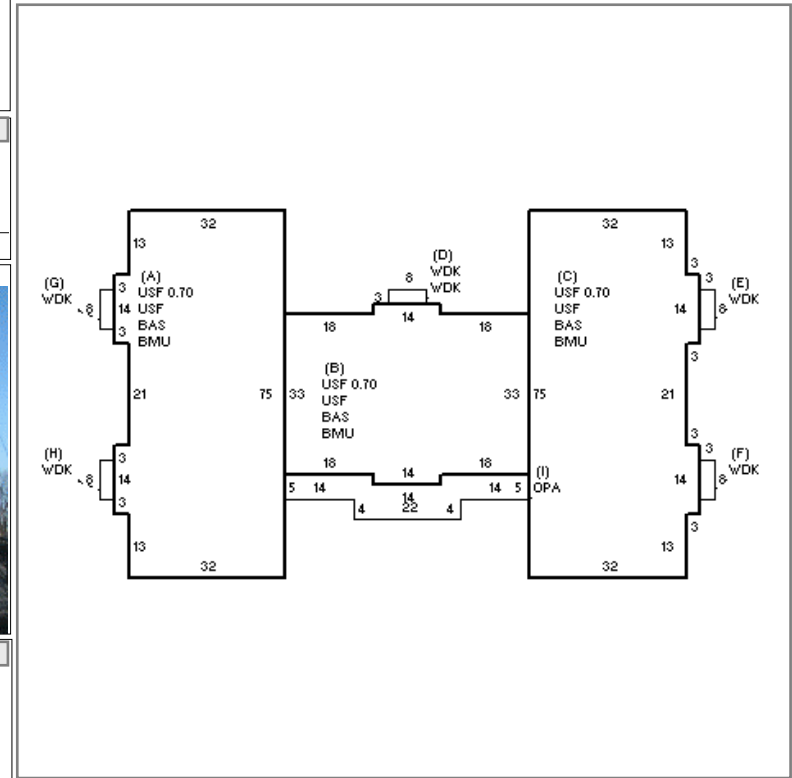

BUILDING

BUILDING	CD	ADJ	DESC	MEASURE	6/11/2018	JD
MODEL	5		CIM-5	LIST	6/11/2018	JD
STYLE	13	0.80	APARTMENTS [100%]	REVIEW		
QUALITY	S	2.10	SUPERLATIVE [100%]			
FRAME	1	1.00	WOOD FRAME [100%]			

YEAR BLT	2018	SIZE ADJ	1.000	ELEMENT	CD	DESCRIPTION	ADJ	S	BAT	T	DESCRIPTION	UNITS	YB	ADJ PRICE	RCN
NET AREA	18,020	DETAIL ADJ	0.825	FOUNDATION	4	FLR & WALL	1.00	+	BMU	N	BSMT UNF	6,674		58.80	392,431
\$NLA(RCN)	\$258	OVERALL	1.000	EXT. COVER	4	VINYL	1.00	+	BAS	L	BASE AREA	6,674	2018	231.58	1,545,570
				ROOF SHAPE	1	GABLE	1.00	+	USF	L	UP-STRY FIN	9,607	2018	231.58	2,224,797
				ROOF COVER	1	ASPH/CMP SHIN	1.00	A	USF	L	UP-STRY FIN	1,739	2108	231.58	402,719
				FLOOR COVER	6	OTHER	1.00	+	WDK	N	WOOD DECK	144		46.20	6,653
				INT. FINISH	1	PLASTER	1.04	I	OPA	N	OPEN PORCH	310		58.80	18,228
				HEATING/COOL	9	WARM/COOL AIR	1.00		ELV	O	PASSGR. ELEV.	1		62,412.00	62,412
				FUEL SOURCE	2	GAS	1.00								

TOTAL RCN	4,652,810
CONDITION ELEM	CD
EXTERIOR	A
INTERIOR	A
CDN/APP	A
EFF.YR/AGE	2018 / 4
COND	4 4 %
FUNC	0
ECON	0
DEPR	4 % GD 96
RCNLD	\$4,466,700

Key: 6262

Town of SCITUATE - Fiscal Year 2024

10/18/2023 5:31 pm SEQ #: 5.961

LEGAL

CURRENT OWNER		PARCEL ID		LOCATION	
RIVER CHASE APARTMENTS LP C/O DAN R LAKS 91 SIDNEY STREET, STE # 207 CAMBRIDGE, MA 02139		53-5-3-0		50 COUNTRY WAY	
TRANSFER HISTORY		DOS	T	SALE PRICE	BK-PG (Cert)

CLASS	CLASS%	DESCRIPTION			BN ID	BN	CARD
0130	85	MULTI-USE RES				3	3 of 3
PMT NO	PMT DT	TY	DESC	AMOUNT	INSP	BY	1st %

LAND

CD	T	AC/SF/UN	Ngh	Inf1	Inf2	ADJ BASE	SAF	Inf3	Lpi	VC	CREDIT AMT	ADJ VALUE
----	---	----------	-----	------	------	----------	-----	------	-----	----	------------	-----------

TOTAL	ZONING	FRNT	ASSESSED	CURRENT	PREVIOUS
Ngh	NOTE		LAND	1,995,400	
Inf1			BUILDING		
Inf2			DETACHED		
			OTHER		
			TOTAL		

DETACHED

TY	QUAL	COND	DIM/NOTE	YB	UNITS	ADJ PRICE	RCNLD	PHOTO
								01/20/2022



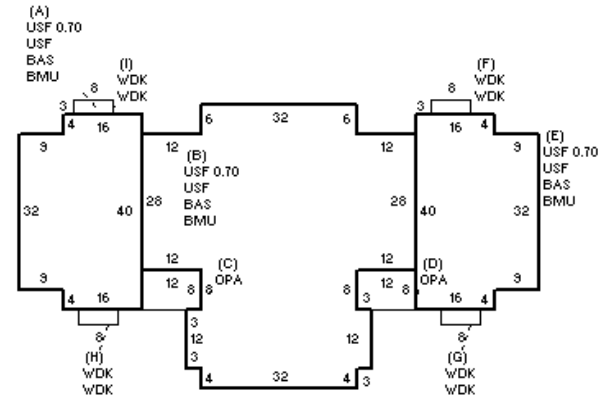

BUILDING

BUILDING	CD	ADJ	DESC	MEASURE	5/22/2018	JD
MODEL	5		CIM-5	LIST	5/28/2018	JD
STYLE	13	0.80	APARTMENTS [100%]	REVIEW	6/11/2018	JD
QUALITY	S	2.10	SUPERLATIVE [100%]			
FRAME	1	1.00	WOOD FRAME [100%]			

YEAR BLT	0	SIZE ADJ	1.000	ELEMENT	CD	DESCRIPTION	ADJ	S	BAT	T	DESCRIPTION	UNITS	YB	ADJ PRICE	RCN
NET AREA	12,031	DETAIL ADJ	0.794	FOUNDATION	4	FLR & WALL	1.00	+	BMU	N	BSMT UNF	4,456		58.80	262,013
\$NLA(RCN)	\$259	OVERALL	1.000	EXT. COVER	4	VINYL	1.00	+	BAS	L	BASE AREA	4,456	0	230.51	1,027,150
CAPACITY				ROOF SHAPE	1	GABLE	1.00	+	USF	L	UP-STRY FIN	7,575	0	230.51	1,746,109
STORIES	3		1.00	ROOF COVER	1	ASPH/CMP SHIN	1.00	+	OPA	N	OPEN PORCH	192		58.80	11,290
% HEATED	100		1.00	FLOOR COVER	6	OTHER	1.00	+	WDK	N	WOOD DECK	192		46.20	8,870
% AIR COND	100		1.03	INT. FINISH	2	DRYWALL	1.00		ELV	O	PASSGR. ELEV.	1		62,412.00	62,412
% SPRINKLER	100		1.02	HEATING/COOL	9	WARM/COOL AIR	1.00								
				FUEL SOURCE	2	GAS	1.00								

BLDG COMMENTS		Building C	
TOTAL RCN		3,117,844	
CONDITION ELEM		CD	
EXTERIOR		A	
INTERIOR		A	
CDN/APP		A	
EFF. YR/AGE		1977 / 45	
COND	36	36 %	
FUNC	0		
ECON	0		
DEPR	36	% GD	64
RCNLD		\$1,995,400	