

Key: 6393

Town of SCITUATE - Fiscal Year 2024

10/18/2023 5:31 pm SEQ #: 6.096

LEGALS

CURRENT OWNER				PARCEL ID				LOCATION				
GAJEWSKI MARK & MEGAN E				55-5-16-0				85 KENT ST				
85 KENT ST				TRANSFER HISTORY				DOS T SALE PRICE BK-PG (Cert)				
SCITUATE, MA 02066				GAJEWSKI MARK & MEGAN E				04/28/2008 F 1 35896-316				
				GAJEWSKI MEGAN				06/29/2004 A 1 28555-300				
				MEE ROSEMARY J TRUSTEE				09/01/1994 F 1 13117-195				
CD	T	AC/SF/UN	Ngh	Infl1	Infl2	ADJ BASE	SAF	Infl3	Lpi	VC	CREDIT AMT	ADJ VALUE
100	S	27,817	HBR 1.00	100	1.00	100	1.00	616,000	1.38	100	1.00	543,990

LAND

TOTAL	27,817 SF	ZONING	FRNT	101	ASSESSED	CURRENT	PREVIOUS
Ngh	HARBOR	NOTE			LAND	544,000	459,200
Infl1	FACTOR 100		BUILDING	809,200	759,500		
Infl2	PHY 100		DETACHED	500	500		
			OTHER	0	0		
					TOTAL	1,353,700	1,219,200

DETAILED

TY	QUAL	COND	DIM/NOTE	YB	UNITS	ADJ PRICE	RCNLD
SHF	A	1.00	30 0.70		40	17.03	500



BUILDING

BUILDING	CD	ADJ	DESC	MEASURE	6/1/2009	SJ
MODEL	1		RESIDENTIAL	LIST	6/1/2009	SJ
STYLE	5	1.00	COLONIAL [100%]	REVIEW	3/17/2011	ER
QUALITY	G	1.20	GOOD [100%]			
FRAME	1	1.00	WOOD FRAME [100%]			

BLDG COMMENTS

CLASS	CLASS%	DESCRIPTION			BN ID	BN	CARD	
1010	100	SINGLE FAMILY				1	1 of 1	
PMT NO	PMT DT	TY	DESC	AMOUNT	INSP	BY	1st	%
08-449	09/18/2008	4	DEMO		06/01/2009	SJ	100	100
08-449	09/18/2008	1	NEW CONST	340,000	06/01/2009	SJ	100	100
08-449	09/18/2008	1	NEW CONST	340,000	06/08/2010	SJ	100	100
08-449	09/18/2008	1	NEW CONST	340,000	08/08/2011	SJ	100	100
09-449	09/18/2008	1	NEW CONST	340,000	08/27/2012	SJ	100	100

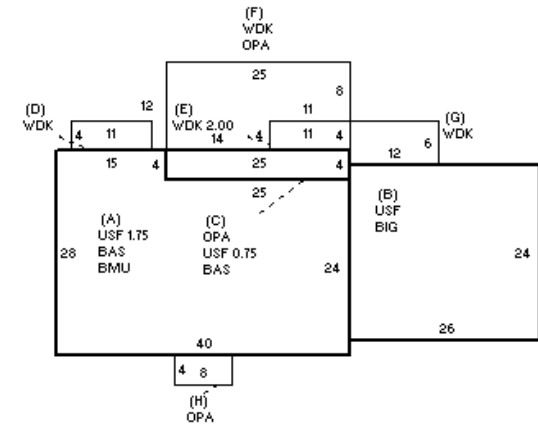

LOADING

YEAR BLT	2009	SIZE ADJ	1.000	ELEMENT	CD	DESCRIPTION	ADJ	S	BAT	T	DESCRIPTION	UNITS	YB	ADJ PRICE	RCN	TOTAL RCN	930,097													
NET AREA	3,604	DETAIL ADJ	1.030	FOUNDATION	4	CONT BSMT WALL	1.00	A	BMU	N	BSMT UNFINISHED	1,020		56.28	57,404															
\$NLA(RCN)	\$258	OVERALL	1.000	EXT COVER	1	WD SHINGLES	1.00	+	USF	L	UPPER STORY FIN	2,484	2009	208.03	516,757															
				ROOF SHAPE	1	GABLE	1.00	B	BIG	N	BUILT-IN GARAGE	624		51.78	32,312															
				ROOF COVER	1	ASPH SHINGLES	1.00	+	BAS	L	BASE AREA	1,120	2009	228.76	256,213															
				FLOOR COVER	13	COMB	1.00	+	WDK	N	WOOD DECK	460		46.00	21,197															
				INT FINISH	2	DRYWALL	1.00	+	OPA	N	OPEN PORCH	388		61.80	23,978															
				HEATING/COOLING	9	WARM/COOL AIR	1.03		GFP	O	GAS FIREPLACE	2		6,667.80	13,336															
				FUEL SOURCE	2	GAS	1.00																							
<table border="1"> <thead> <tr> <th>CONDITION ELEM</th> <th>CD</th> </tr> </thead> <tbody> <tr> <td>EXTERIOR</td> <td></td> </tr> <tr> <td>INTERIOR</td> <td></td> </tr> <tr> <td>KITCHEN</td> <td></td> </tr> <tr> <td>BATHS</td> <td></td> </tr> <tr> <td>HEAT</td> <td></td> </tr> <tr> <td>ELECT</td> <td></td> </tr> </tbody> </table>																CONDITION ELEM	CD	EXTERIOR		INTERIOR		KITCHEN		BATHS		HEAT		ELECT		
CONDITION ELEM	CD																													
EXTERIOR																														
INTERIOR																														
KITCHEN																														
BATHS																														
HEAT																														
ELECT																														
<table border="1"> <thead> <tr> <th>EFF.YR/AGE</th> <th colspan="2">2009 / 13</th> </tr> </thead> <tbody> <tr> <td>COND</td> <td>13</td> <td>13 %</td> </tr> <tr> <td>FUNC</td> <td>0</td> <td></td> </tr> <tr> <td>ECON</td> <td>0</td> <td></td> </tr> <tr> <td>DEPR</td> <td>13</td> <td>% GD 87</td> </tr> </tbody> </table>																EFF.YR/AGE	2009 / 13		COND	13	13 %	FUNC	0		ECON	0		DEPR	13	% GD 87
EFF.YR/AGE	2009 / 13																													
COND	13	13 %																												
FUNC	0																													
ECON	0																													
DEPR	13	% GD 87																												
<table border="1"> <thead> <tr> <th>RCNLD</th> <th>\$809,200</th> </tr> </thead> </table>																RCNLD	\$809,200													
RCNLD	\$809,200																													