

Key: 646

Town of SCITUATE - Fiscal Year 2024

10/18/2023 5:31 pm SEQ #: 584

LEG
AL

L
A
N
D

CURRENT OWNER				PARCEL ID				LOCATION				
BAEZ ATILIO B & ANN A 341 FIRST PARISH RD SCITUATE, MA 02066				37-1-3-0				341 FIRST PARISH RD				
TRANSFER HISTORY				DOS	T	SALE PRICE	BK-PG (Cert)					
BAEZ ATILIO B & ANN A				07/08/2010	QS	570,000	38713-69					
TREVLEX CONSTRUCTION CO.				07/08/2010	B		38711-1-14					
TREVLEX CONSTRUCTION CO.				06/11/2008	O	391,000	36066-150					
CD	T	AC/SF/UN	Ngh	Inf1	Inf2	ADJ BASE	SAF	Inf3	Lpi	VC	CREDIT AMT	ADJ VALUE

CLASS	CLASS%	DESCRIPTION			BN ID	BN	CARD	
1020	100	CONDOMINIUM				1	1 of 1	
PMT NO	PMT DT	TY	DESC	AMOUNT	INSP	BY	1st	%
11-759		3	ALTERATIONS	365	07/31/2012	SJ	100	100
		1	NEW CONST		04/27/2011	SJ	100	100
		1	NEW CONST		04/28/2010	SJ	100	100
		1	NEW CONST		05/15/2009	SJ	100	100
07-451	08/09/2007	4	DEMO		06/02/2008	SJ	100	100

D
E
T
A
C
H
E
D

TOTAL	SF	ZONING	FRNT	24	ASSESSED	CURRENT	PREVIOUS
Ngh		NOTE ... MASTER DEED FY2012			LAND	0	0
Inf1			BUILDING	866,300	800,800		
Inf2			DETACHED	0	0		
			OTHER	0	0		
					TOTAL	866,300	800,800

TY	QUAL	COND	DIM/NOTE	YB	UNITS	ADJ PRICE	RCNLD

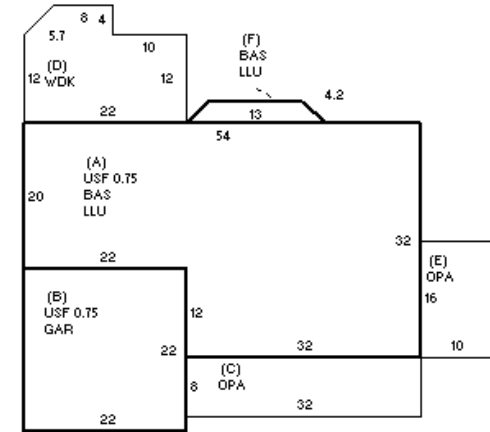

B
U
I
L
D
I
N
G

BUILDING	CD	ADJ	DESC	MEASURE	5/1/2023	NC
MODEL	10		CONDO	LIST	4/27/2011	SJ
STYLE	1	1.00	CONDO [100%]	REVIEW	6/14/2023	MR
QUALITY	+	1.15	GOOD-AVE+ [100%]			
FRAME	1	1.00	WOOD FRAME [100%]			

BLDG COMMENTS

YEAR BLT	2009	SIZE ADJ	1.000	ELEMENT	CD	DESCRIPTION	ADJ	S	BAT	T	DESCRIPTION	UNITS	YB	ADJ PRICE	RCN	TOTAL RCN	902,376														
NET AREA	2,973	DETAIL ADJ	1.020	COMPLEX	83	FIRST PARISH CO	1.00	+	LLU	N	LOWER LEVEL UN	1,512		160.89	243,268																
\$NLA(RCN)	\$304	OVERALL	1.000	STYLE	22	DUPLEX	1.00	+	BAS	L	BAS AREA	1,512	2009	205.12	310,137																
				VIEW/LOC	9	NONE	1.00	+	USF	L	UP-STRY FIN	1,461	2009	205.12	299,675																
				HVAC	9	WARM/COOL AIR	1.02	B	GAR	N	GARAGE	484		43.81	21,206																
				FUEL SOURCE	2	GAS	1.00	+	OPA	N	OPEN PORCH	416		28.06	11,673																
				FLOOR LEVEL	5	END UNIT	1.00	D	WDK	N	ATT WOOD DECK	304		21.85	6,642																
				CONDO MODEL	99		1.00		GFP	O	GAS FIREPLACE	1		3,247.60	3,248																
				INT QUALITY	0		1.00																								
<table border="1"> <thead> <tr> <th>CONDITION ELEM</th> <th>CD</th> </tr> </thead> <tbody> <tr> <td>INTERIOR</td> <td>A</td> </tr> <tr> <td>KITCHEN</td> <td>A</td> </tr> <tr> <td>BATHS</td> <td>A</td> </tr> <tr> <td>EXTERIOR</td> <td>A</td> </tr> </tbody> </table>																	CONDITION ELEM	CD	INTERIOR	A	KITCHEN	A	BATHS	A	EXTERIOR	A					
CONDITION ELEM	CD																														
INTERIOR	A																														
KITCHEN	A																														
BATHS	A																														
EXTERIOR	A																														
<table border="1"> <thead> <tr> <th>EFF.YR/AGE</th> <td colspan="2">2009 / 13</td> </tr> </thead> <tbody> <tr> <td>COND</td> <td>4</td> <td>4 %</td> </tr> <tr> <td>FUNC</td> <td>0</td> <td></td> </tr> <tr> <td>ECON</td> <td>0</td> <td></td> </tr> <tr> <td>DEPR</td> <td>4</td> <td>% GD 96</td> </tr> </tbody> </table>																	EFF.YR/AGE	2009 / 13		COND	4	4 %	FUNC	0		ECON	0		DEPR	4	% GD 96
EFF.YR/AGE	2009 / 13																														
COND	4	4 %																													
FUNC	0																														
ECON	0																														
DEPR	4	% GD 96																													
<table border="1"> <thead> <tr> <th>RCNLD</th> <td>\$866,300</td> </tr> </thead> </table>																	RCNLD	\$866,300													
RCNLD	\$866,300																														