

Key: 6553

Town of SCITUATE - Fiscal Year 2024

10/18/2023 5:31 pm SEQ #: 6.255

LEGAL

LAND

DETACHED

BUILDING

CURRENT OWNER				PARCEL ID				LOCATION			
HUDDLESTON JOSHUA P & JONES ALISSA C 14 PEGGOTTY BEACH RD SCITUATE, MA 02066				55-7-16-B				14 PEGGOTTY BEACH RD			
TRANSFER HISTORY				DOS	T	SALE PRICE		BK-PG (Cert)			
HUDDLESTON JOSHUA P & LUDWIG VINTON H & BETH S				11/20/2018	QS	674,900 (116715)					
FRAWLEY AUSTINE P				11/10/2011	QS	499,000 (116715)					
				05/12/1998	F	-100 (93310)					

CLASS	CLASS%	DESCRIPTION		BN ID	BN	CARD	
1010	100	SINGLE FAMILY			1	1 of 1	
PMT NO	PMT DT	TY	DESC	AMOUNT	INSP	BY	1st %
21-1332	10/12/2021	2	ADDITIONS	96,500	07/26/2022	JD	100 90
21-1332	10/12/2021	2	ADDITIONS	96,500	08/28/2023	JD	100 100
15-348	06/15/2015	3	ALTERATIONS	52,000	08/02/2016	SJ	100 10
15-348	06/15/2015	3	ALTERATIONS	52,000	08/29/2017	SJ	100 100
07-693	11/20/2007	3	ALTERATIONS	6,500	06/18/2008	SJ	100 100

TOTAL	1.400 Acres	ZONING	FRNT	96	ASSESSED	CURRENT	PREVIOUS
Ngh	CLIFFS	N O T E	IN M56		LAND	556,000	505,800
Inf1	FACTOR 100		LAND	531,000	421,100		
Inf2	PHY 100		DETACHED	2,000	1,900		
			OTHER	0	0		
			TOTAL	1,089,000	928,800		

TY	QUAL	COND	DIM/NOTE	YB	UNITS	ADJ PRICE	RCNLD
SHF	G	1.20	10 0.90 14X10	1986	140	16.00	2,000

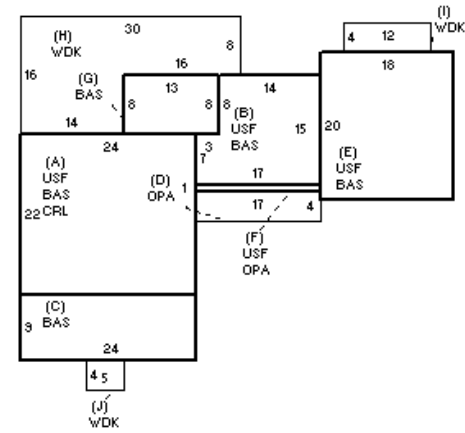

BUILDING	CD	ADJ	DESC	MEASURE	8/27/2019	JD
MODEL	1		RESIDENTIAL	LIST	8/27/2019	EST
STYLE	7	1.20	CONVENTIONAL [100%]	REVIEW	8/28/2023	JD
QUALITY	A	1.00	AVERAGE [100%]			
FRAME	1	1.00	WOOD FRAME [100%]			

BLDG COMMENTS

YEAR BLT	1920	SIZE ADJ	1.000	ELEMENT	CD	DESCRIPTION	ADJ	S	BAT	T	DESCRIPTION	UNITS	YB	ADJ PRICE	RCN	TOTAL RCN	639,757			
NET AREA	2,575	DETAIL ADJ	1.248	FOUNDATION	4	CONT BSMT WALL	1.00	A	CRL	N	BSMT CRAWL	528		13.22	6,978	CONDITION ELEM	CD			
\$NLA(RCN)	\$248	OVERALL	1.000	EXT COVER	1	WD SHINGLES	1.00	+	USF	L	UPPER STORY FIN	905	1920	219.38	198,543	EXTERIOR	V			
				ROOF SHAPE	1	GABLE	1.00	+	BAS	L	BASE AREA	1,335	1920	241.24	322,059	INTERIOR	G			
				ROOF COVER	1	ASPH SHINGLES	1.00	B	USF	L	UPPER STORY FIN	231	2022	219.39	50,678	KITCHEN	V			
				FLOOR COVER	2	SOFTWOOD	1.00	+	OPA	N	OPEN PORCH	85		51.51	4,378	BATHS	G			
				INT FINISH	1	PLASTER	1.00	G	BAS	L	BASE AREA	104	2022	241.24	25,089	HEAT	A			
				HEATING/COOLING	11	HW/COOL AIR	1.04	+	WDK	N	WOOD DECK	420		38.40	16,128	ELECT	A			
				FUEL SOURCE	2	GAS	1.00	F21	O	FPL 2S 1OP	1		8,239.00	8,239						
								ODS	O	OUT DOOR SHOWER	1		1,675.00	1,675						
																		EFF.YR/AGE	2005 / 17	
																		COND	17 17 %	
																		FUNC	0	
																		ECON	0	
																		DEPR	17 % GD 83	
																		RCNLD	\$531,000	