

Key: 6575

Town of SCITUATE - Fiscal Year 2024

10/18/2023 5:31 pm SEQ #: 6.279

LEGAL

CURRENT OWNER				PARCEL ID				LOCATION			
MCDONOUGH LEO 16 SALT MEADOW LN SCITUATE, MA 02066				57-2-5-B				16 SALT MEADOW LN			
TRANSFER HISTORY				DOS	T	SALE PRICE	BK-PG (Cert)				
MCDONOUGH LEO				09/19/2019	H	1	51661-52				
MCDONOUGH LEO & JANET				10/17/2006	V	785,000	33528-5				
ILACQUA FERDINAND				01/01/1983	QS	7,500	5441-307				

CLASS	CLASS%	DESCRIPTION			BN ID	BN	CARD	
1010	100	SINGLE FAMILY				1	1 of 1	
PMT NO	PMT DT	TY	DESC	AMOUNT	INSP	BY	1st	%
07-726	05/24/2007	2	ADDITIONS	180,000	08/09/2007	SJ	100	100
07-726	05/24/2007	2	ADDITIONS	180,000	08/25/2009	SJ	100	100
07-726	05/04/2007	2	ADDITIONS	180,000	08/05/2007	SJ	100	100
		6	CYCL GROWTH				100	100

LAND

CD	T	AC/SF/UN	Ngh	Inf1	Inf2	ADJ BASE	SAF	Inf3	Lpi	VC	CREDIT AMT	ADJ VALUE	
100	S	35,300	GB	1.00	1.00	1.00	1.00	440,000	1.12	100	1.00	R05 1.00	398,140

DETACHED

TOTAL	35,300 SF	ZONING	FRNT	195	ASSESSED	CURRENT	PREVIOUS
Ngh	GREENBUSH	NOTE	LAND	398,100	362,000		
Inf1	FACTOR 100		BUILDING	674,200	623,200		
Inf2	PHY 100		DETACHED	0	0		
			OTHER	0	0		
			TOTAL	1,072,300	985,200		

TY	QUAL	COND	DIM/NOTE	YB	UNITS	ADJ PRICE	RCNLD

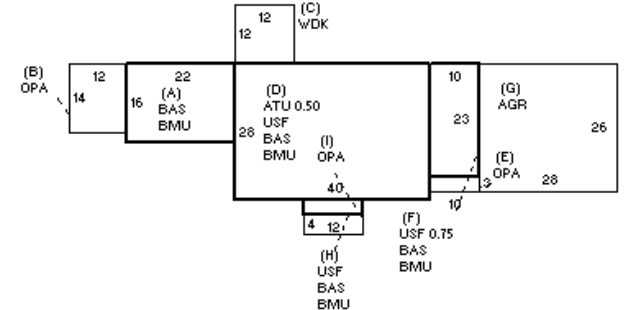

BLDG COMMENTS

BUILDING

BUILDING	CD	ADJ	DESC	MEASURE	8/25/2009	SJ
MODEL	1		RESIDENTIAL	LIST	8/25/2009	EST
STYLE	5	1.00	COLONIAL [100%]	REVIEW	3/16/2011	ER
QUALITY	G	1.20	GOOD [100%]			
FRAME	1	1.00	WOOD FRAME [100%]			

YEAR BLT	1964	SIZE ADJ	1.000	ELEMENT	CD	DESCRIPTION	ADJ	S	BAT	T	DESCRIPTION	UNITS	YB	ADJ PRICE	RCN	TOTAL RCN	875,527
NET AREA	3,067	DETAIL ADJ	1.020	FOUNDATION	4	CONT BSMT WALL	1.00	+	BMU	N	BSMT UNFINISHED	1,738		49.71	86,399		
\$NLA(RCN)	\$285	OVERALL	1.000	EXT COVER	1	WD SHINGLES	1.00	+	BAS	L	BASE AREA	1,738	1964	230.93	401,352		
				ROOF SHAPE	1	GABLE	1.00	+	OPA	N	OPEN PORCH	246		61.80	15,203		
				ROOF COVER	1	ASPH SHINGLES	1.00	C	WDK	N	WOOD DECK	144		46.08	6,636		
				FLOOR COVER	34	COMB	1.00	+	USF	L	UPPER STORY FIN	1,329	1964	210.00	279,095		
				INT FINISH	1	PLASTER	1.00	D	ATU	N	ATTIC UNF	560		44.40	24,864		
				HEATING/COOLING	2	HOT WATER	1.02	G	AGR	N	ATT GARAGE	728		48.79	35,521		
				FUEL SOURCE	99	N/A	1.00	F11	O	FPL 1S 1OP	1			8,737.20	8,737		
								F21	O	FPL 2S 1OP	1			9,886.80	9,887		

CONDITION ELEM	CD
EXTERIOR	
INTERIOR	
KITCHEN	
BATHS	
HEAT	
ELECT	

EFF.YR/AGE	1995 / 27
COND	23 23 %
FUNC	0
ECON	0
DEPR	23 % GD 77

RCNLD	\$674,200
-------	-----------