

Key: 6603

Town of SCITUATE - Fiscal Year 2024

10/18/2023 5:31 pm SEQ #: 6.306

LEGAL

CURRENT OWNER		PARCEL ID		LOCATION	
CARMODY JAMES S III & KARI A 1320 CARY WAY SAN DIEGO, CA 92109		58-1-4-A		160 C J CUSHING WAY	
TRANSFER HISTORY		DOS	T	SALE PRICE	BK-PG (Cert)
CARMODY JAMES S III & KAR		09/03/2021	O	595,000	55602-197
HARRIS SHAWN TR		10/25/2017	U	175,000	49090-345
DUANE JAS AMBROSE JR TRUS		06/05/1997	F	1	15228-186

CLASS	CLASS%	DESCRIPTION		BN ID	BN	CARD	
1010	100	SINGLE FAMILY			1	1 of 1	
PMT NO	PMT DT	TY	DESC	AMOUNT	INSP	BY	1st %
23-193	03/07/2023	3	ALTERATIONS	38,000	05/23/2023	NC	100 100
23-0031	01/10/2023	3	ALTERATIONS	15,000	05/23/2023	NC	100 100
22-0252	03/11/2022	3	ALTERATIONS	96,450	08/02/2022	JD	100 50
22-0252	03/11/2022	3	ALTERATIONS	96,450	05/23/2023	NC	100 100
18-519	08/09/2018	3	ALTERATIONS	6,000	06/05/2019	TCK	100 65

LAND

CD	T	AC/SF/UN	Ngh	Infl1	Infl2	ADJ BASE	SAF	Infl3	Lpi	VC	CREDIT AMT	ADJ VALUE
100	S	40,000 GB	1.00	100	1.00	457,600	1.00	80	0.80	RF1	1.30	420,200
300	A	2.452 GB	1.00	100	1.00	5,148	1.00	W20	0.20	RF1	1.30	12,620

TOTAL	3.370 Acres	ZONING	FRNT	0	ASSESSED	CURRENT	PREVIOUS
Ngh	GREENBUSH	NOTE INF3=ACCESS EASEMENT/WETLANDS	LAND	432,800	394,100		
Infl1	FACTOR 100		BUILDING	426,600	242,900		
Infl2	PHY 100		DETACHED	0	0		
			OTHER	0	0		
			TOTAL	859,400	637,000		

DETACHED

TY	QUAL	COND	DIM/NOTE	YB	UNITS	ADJ PRICE	RCNLD	PHOTO
								05/23/2023

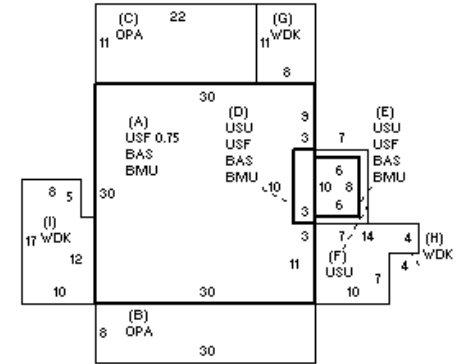
BUILDING

BUILDING	CD	ADJ	DESC	MEASURE	6/5/2019	TCK
MODEL	1		RESIDENTIAL	LIST	6/5/2019	TCK
STYLE	5	1.00	COLONIAL [100%]	REVIEW	8/2/2022	JD
QUALITY	+	1.10	AVG +/GOOD - [100%]			
FRAME	1	1.00	WOOD FRAME [100%]			

YEAR BLT	1971	SIZE ADJ	1.000	ELEMENT	CD	DESCRIPTION	ADJ	S	BAT	T	DESCRIPTION	UNITS	YB	ADJ PRICE	RCN	TOTAL RCN	501,868		
NET AREA	1,679	DETAIL ADJ	1.050	FOUNDATION	4	CONT BSMT WALL	1.00	+	BMU	N	BSMT UNFINISHED	948		52.70	49,960				
\$NLA(RCN)	\$299	OVERALL	1.000	EXT COVER	1	WD SHINGLES	1.00	+	BAS	L	BASE AREA	948	1971	238.12	225,735				
				ROOF SHAPE	1	GABLE	1.00	+	USF	L	UPPER STORY FIN	731	1971	216.54	158,292		EXTERIOR	G	
				ROOF COVER	2	WOOD SHINGLES	1.01	+	OPA	N	OPEN PORCH	482		56.65	27,305			INTERIOR	G
				FLOOR COVER	14	COMB	1.00	+	USU	N	UPPER STORY UNF	100		95.45	9,545			KITCHEN	G
				INT FINISH	2	DRYWALL	1.00	+	WDK	N	WOOD DECK	374		42.24	15,798			BATHS	G
				HEATING/COOLING	11	HW/COOL AIR	1.04		F21	O	FPL 2S 1OP	1		9,062.90	9,063			BATHS	G
				FUEL SOURCE	1	OIL	1.00		ODS	O	OUT DOOR SHOWER	1		1,549.90	1,550			HEAT	U
																		ELECT	U

CONDITION ELEM	CD
EXTERIOR	G
INTERIOR	G
KITCHEN	G
BATHS	G
HEAT	U
ELECT	U
EFF.YR/AGE	2007 / 15
COND	15 15%
FUNC	0
ECON	0
DEPR	15 % GD 85
RCNLD	\$426,600