

Key: 6620

Town of SCITUATE - Fiscal Year 2024

10/18/2023 5:31 pm SEQ #: 6.321

LEGAL

LAND

DETACHED

BUILDING

CURRENT OWNER		PARCEL ID		LOCATION	
YARDLEY THOMAS & ABIGAIL 20 NEAL GATE ST SCITUATE, MA 02066		58-2-2-0		20 NEAL GATE ST	
TRANSFER HISTORY		DOS	T	SALE PRICE	BK-PG (Cert)
YARDLEY THOMAS & ABIGAIL		11/09/2020	QS	1,395,000	53791-192
CARMELLO STEPHEN J, JR		11/29/2005	QS	925,000	31805-2
BYRNE RAYMOND E JR		12/16/2002	F	1	23686-4

CLASS	CLASS%	DESCRIPTION		BN ID	BN	CARD	
1010	100	SINGLE FAMILY			1	1 of 1	
PMT NO	PMT DT	TY	DESC	AMOUNT	INSP	BY	1st %
07-127	03/28/2007	3	ALTERATIONS	60,000	08/09/2007	SJ	100 100
06-168	04/04/2006	3	ALTERATIONS	25,000	09/05/2006	SJ	100 100
97-380	07/03/1997	3	ALTERATIONS				100 100
93-418	07/15/1993	3	ALTERATIONS				100 100
92-523	06/01/1992	3	ALTERATIONS				100 100

CD	T	AC/SF/UN	Ngh	Infl1	Infl2	ADJ BASE	SAF	Infl3	Lpi	VC	CREDIT AMT	ADJ VALUE
100	S	40,000	GB 1.00	100	1.00	572,000	1.00	100	1.00	RV2	1.30	525,250
300	A	0.001	GB 1.00	100	1.00	25,740	1.00	100	1.00	RV2	1.30	30

TOTAL	40,031 SF	ZONING	FRNT	157	ASSESSED	CURRENT	PREVIOUS
Ngh	GREENBUSH	NOTE			LAND	525,300	477,500
Infl1	FACTOR 100		BUILDING	1,070,800	952,400		
Infl2	PHY 100		DETACHED	20,000	19,000		
			OTHER	0	0		
			TOTAL		1,616,100	1,448,900	

TY	QUAL	COND	DIM/NOTE	YB	UNITS	ADJ PRICE	RCNLD
IPG	G	1.20 30 0.70		1997	680	42.03	20,000

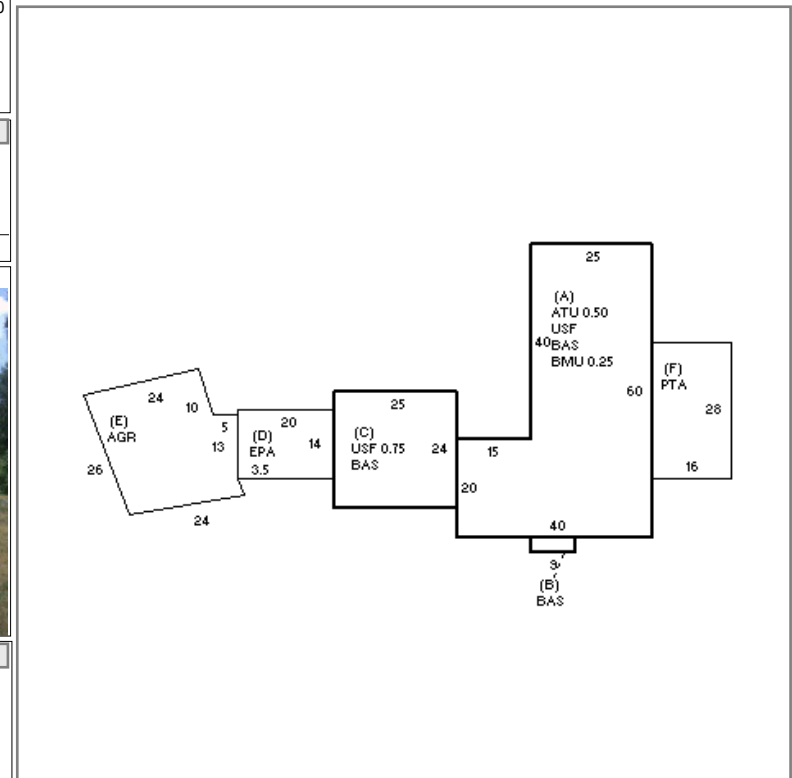

BUILDING	CD	ADJ	DESC	MEASURE	10/13/2015	SJ
MODEL	1		RESIDENTIAL	LIST	10/13/2015	EST
STYLE	19	1.15	ANTIQUE [100%]	REVIEW	8/8/2022	JD
QUALITY	G	1.20	GOOD [100%]			
FRAME	1	1.00	WOOD FRAME [100%]			

BLDG COMMENTS
MLS

YEAR BLT	1742	SIZE ADJ	1.000	ELEMENT	CD	DESCRIPTION	ADJ	S	BAT	T	DESCRIPTION	UNITS	YB	ADJ PRICE	RCN	TOTAL RCN	1,338,446			
NET AREA	4,677	DETAIL ADJ	1.196	FOUNDATION	4	CONT BSMT WALL	1.00	A	BMU	N	BSMT UNFINISHED	450		75.78	34,102	CONDITION ELEM	CD			
\$NLA(RCN)	\$286	OVERALL	1.000	EXT COVER	1	WD SHINGLES	1.00	+	USF	L	UPPER STORY FIN	2,250	1742	235.23	529,277	EXTERIOR	G			
				ROOF SHAPE	1	GABLE	1.00	A	ATU	N	ATTIC UNF	900		44.40	39,960	INTERIOR	G			
				ROOF COVER	1	ASPH SHINGLES	1.00	+	BAS	L	BASE AREA	2,427	1742	258.67	627,797	KITCHEN	V			
				FLOOR COVER	2	SOFTWOOD	1.00	D	EPA	N	ENCLOSED PORCH	280		108.24	30,307	BATHS	V			
				INT FINISH	1	PLASTER	1.00	E	AGR	N	ATT GARAGE	657		49.74	32,682	HEAT	A			
				HEATING/COOLING	11	HW/COOL AIR	1.04	F	PTA	N	PATIO	448		17.88	8,010	ELECT	U			
				FUEL SOURCE	2	GAS	1.00		F34	O	FPL 3S 4OP	1		23,682.00	23,682					
																	EFF.YR/AGE	2002 / 20		
																	COND	18 18%		
																	FUNC	0		
																	ECON	0		
																	DEPR	20	% GD	80
																	RCNLD	\$1,070,800		