

Key: 6665

Town of SCITUATE - Fiscal Year 2024

10/18/2023 5:31 pm SEQ #: 6.362

LEG
A
L

L
A
N
D

CURRENT OWNER				PARCEL ID				LOCATION				
MURRAY PATRICK W & SUZANNE S 14 ELAINE COURT SCITUATE, MA 02066				60-1-15-0				14 TOWN WAY				
TRANSFER HISTORY				DOS	T	SALE PRICE	BK-PG (Cert)					
MURRAY PATRICK W & SUZANN				08/20/2021	O	725,000	55511-30					
SINGH, PRAMOD K				01/13/2011	F	1	39537-162					
SYNDER PRAMOD SINGH				09/24/2001	O	285,000	20580-183					
CD	T	AC/SF/UN	Ngh	Inf1	Inf2	ADJ BASE	SAF	Inf3	Lpi	VC	CREDIT AMT	ADJ VALUE
100	S	23,678	CLF 1.00	100	1.00	660,000	1.60	100	1.00	WV3	1.50	574,440

CLASS	CLASS%	DESCRIPTION			BN ID	BN	CARD	
1010	100	SINGLE FAMILY				1	1 of 1	
PMT NO	PMT DT	TY	DESC	AMOUNT	INSP	BY	1st	%
23-196	03/08/2023	3	ALTERATIONS	40,000	05/10/2023	JD	100	0
21-1368	10/25/2021	1	NEW CONST	567,000	04/27/2022	JD	100	50
21-1368	10/25/2021	1	NEW CONST	567,000	05/10/2023	JD	100	100
11-454	07/26/2011	3	ALTERATIONS	29,000	08/30/2012	SJ	100	100
98-251	06/08/1998	3	ALTERATIONS				100	100

D
E
T
A
C
H
E
D

TOTAL	23,678 SF	ZONING	FRNT	12	ASSESSED	CURRENT	PREVIOUS
Ngh	CLIFFS	N O T E			LAND	574,400	522,200
Inf1	FACTOR 100		BUILDING	978,800	375,100		
Inf2	PHY 100		DETACHED	10,600	100		
			OTHER	0	0		
			TOTAL		1,563,800	897,400	

TY	QUAL	COND	DIM/NOTE	YB	UNITS	ADJ PRICE	RCNLD
HTB	E	1.80	10 0.90 PLUNGE POOL	2023	1	9,327.24	8,400
PTD	A	1.00	10 0.90 20X16	2023	320	7.81	2,200

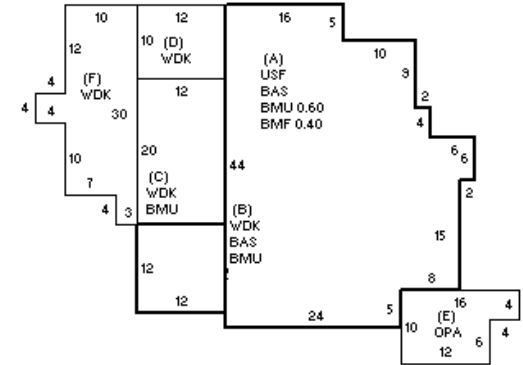

B
U
I
L
D
I
N
G

BUILDING	CD	ADJ	DESC	MEASURE	4/27/2022	JD
MODEL	1		RESIDENTIAL	LIST	4/27/2022	EST
STYLE	20	1.35	NEW STYLE [100%]	REVIEW	5/10/2023	JD
QUALITY	G	1.20	GOOD [100%]			
FRAME	1	1.00	WOOD FRAME [100%]			

BLDG COMMENTS

YEAR BLT	2022	SIZE ADJ	1.000	ELEMENT	CD	DESCRIPTION	ADJ	S	BAT	T	DESCRIPTION	UNITS	YB	ADJ PRICE	RCN	TOTAL RCN	978,769	
NET AREA	2,604	DETAIL ADJ	1.390	FOUNDATION	4	CONT BSMT WALL	1.00	A	BMF	N	BSMT FINISH-SEP	492		70.78	34,823	CONDITION ELEM	CD	
\$NLA(RCN)	\$376	OVERALL	1.000	EXT COVER	2	CLAPBOARD	1.00	+	BAS	L	BASE AREA	1,374	2022	321.73	442,054	EXTERIOR	A	
				ROOF SHAPE	1	GABLE	1.00	A	USF	L	UPPER STORY FIN	1,230	2022	292.58	359,869	INTERIOR	A	
				ROOF COVER	1	ASPH SHINGLES	1.00	+	BMU	N	BSMT UNFINISHED	1,122		50.42	56,570	KITCHEN	A	
				FLOOR COVER	1	HARDWOOD	1.00	+	WDK	N	WOOD DECK	792		46.08	36,496	BATHS	A	
				INT FINISH	2	DRYWALL	1.00	E	OPA	N	OPEN PORCH	136		61.80	8,405	HEAT	A	
				HEATING/COOLING	9	WARM/COOL AIR	1.03		BMG	O	BSMT GARAGE	3		2,988.80	8,966	ELECT	A	
				FUEL SOURCE	2	GAS	1.00		GEN	O	GENERATOR	1		0.00				
										GFP	O	GAS FIREPLACE	2		6,667.80	13,336		
										ODS	O	OUT DOOR SHOWER	1		2,238.00	2,238		
														EFF.YR/AGE	2022 / 0			
														COND	0 0 %			
														FUNC	0			
														ECON	0			
														DEPR	0 % GD 100			
														RCNLD	\$978,800			