

Key: 6696

Town of SCITUATE - Fiscal Year 2024

10/18/2023 5:31 pm SEQ #: 6.394

LEGAL

LAND

DETACHED

BUILDING

| CURRENT OWNER | | | | PARCEL ID | | | | LOCATION | | | | |
|---|---|----------|----------|------------|------|------------|--------------|--------------|------|-----|------------|-----------|
| SAKELLARIS PETER ARTHUR 79 GILSON RD SCITUATE, MA 02066 | | | | 60-1-47-0 | | | | 79 GILSON RD | | | | |
| TRANSFER HISTORY | | | | DOS | T | SALE PRICE | BK-PG (Cert) | | | | | |
| SAKELLARIS PETER ARTHUR | | | | 01/18/2022 | QS | 2,785,000 | 56324-24 | | | | | |
| LAURIDSEN NANCY G TR | | | | 12/15/2016 | QS | 2,500,000 | 47883-157 | | | | | |
| FOGARTY JANET R TRUSTEE | | | | 03/14/2003 | F | 100 | 24495-260 | | | | | |
| CD | T | AC/SF/UN | Ngh | Inf1 | Inf2 | ADJ BASE | SAF | Inf3 | Lpi | VC | CREDIT AMT | ADJ VALUE |
| 100 | S | 13,550 | CLF 1.00 | 100 | 1.00 | 1,672,000 | 2.69 | 100 | 1.00 | WF3 | 3.80 | 1,397,040 |

| CLASS | CLASS% | DESCRIPTION | | BN ID | BN | CARD | |
|--------|------------|---------------|-------------|---------|------------|--------|---------|
| 1010 | 100 | SINGLE FAMILY | | | 1 | 1 of 1 | |
| PMT NO | PMT DT | TY | DESC | AMOUNT | INSP | BY | 1st % |
| 23-299 | 04/06/2023 | 3 | OTHERS | 22,420 | 08/09/2023 | JD | 100 100 |
| 19-181 | 03/26/2019 | 3 | ALTERATIONS | 75,000 | 08/09/2023 | JD | 100 100 |
| 03-305 | 01/30/2003 | 3 | ALTERATIONS | 425,000 | 08/28/2019 | JD | 100 100 |
| | 01/30/2003 | 4 | DEMO | | 09/20/2004 | SJ | 100 100 |

| TOTAL | 13,547 SF | ZONING | FRNT | 102 | ASSESSED | CURRENT | PREVIOUS |
|-------|------------|----------------------------|----------|-----|-----------|-----------|----------|
| Ngh | CLIFFS | N O T E C/W 46 | LAND | | 1,397,000 | 1,270,000 | |
| Inf1 | FACTOR 100 | | BUILDING | | 1,671,400 | 1,754,600 | |
| Inf2 | PHY 100 | | DETACHED | | 0 | 0 | |
| | | | OTHER | | 0 | 0 | |
| | | | TOTAL | | 3,068,400 | 3,024,600 | |

| TY | QUAL | COND | DIM/NOTE | YB | UNITS | ADJ PRICE | RCNLD |
|----|------|------|----------|----|-------|-----------|-------|
| | | | | | | | |



| BLDG COMMENTS |
|---------------|
| MLS |

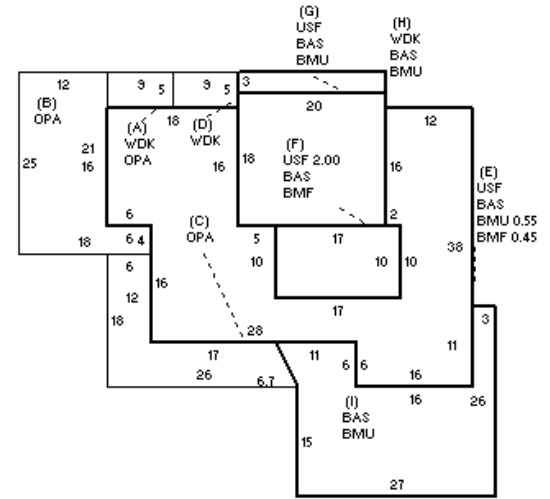

| BUILDING | CD | ADJ | DESC | MEASURE | 8/9/2023 | JD |
|----------|----|------|-------------------|---------|----------|-----|
| MODEL | 1 | | RESIDENTIAL | LIST | 8/9/2023 | EST |
| STYLE | 20 | 1.35 | NEW STYLE [100%] | REVIEW | 9/1/2022 | JD |
| QUALITY | E | 1.80 | EXCELLENT [100%] | | | |
| FRAME | 1 | 1.00 | WOOD FRAME [100%] | | | |

| YEAR BLT | 2003 | SIZE ADJ | 1.000 | ELEMENT | CD | DESCRIPTION | ADJ | S | BAT | T | DESCRIPTION | UNITS | YB | ADJ PRICE | RCN | TOTAL RCN | 2,063,459 |
|------------|-------|------------|-------|-----------------|----|----------------|------|---|-----|---|-----------------|-------|------|-----------|-----------|----------------|-------------|
| NET AREA | 4,005 | DETAIL ADJ | 1.390 | FOUNDATION | 4 | CONT BSMT WALL | 1.00 | + | OPA | N | OPEN PORCH | 588 | | 92.70 | 54,508 | | |
| \$NLA(RCN) | \$515 | OVERALL | 1.000 | EXT COVER | 1 | WD SHINGLES | 1.00 | + | WDK | N | WOOD DECK | 150 | | 69.12 | 10,368 | | |
| | | | | ROOF SHAPE | 1 | GABLE | 1.00 | + | BMF | N | BSMT FINISH-SEP | 670 | | 100.64 | 67,426 | | |
| | | | | ROOF COVER | 1 | ASPH SHINGLES | 1.00 | + | BAS | L | BASE AREA | 2,195 | 2003 | 457.80 | 1,004,875 | | |
| | | | | FLOOR COVER | 13 | COMB | 1.00 | + | USF | L | UPPER STORY FIN | 1,810 | 2003 | 416.32 | 753,543 | | |
| | | | | INT FINISH | 2 | DRYWALL | 1.00 | + | BMU | N | BSMT UNFINISHED | 1,526 | | 71.69 | 109,395 | | |
| | | | | HEATING/COOLING | 9 | WARM/COOL AIR | 1.03 | | BMG | O | BSMT GARAGE | 2 | | 4,483.80 | 8,968 | | |
| | | | | FUEL SOURCE | 2 | GAS | 1.00 | | F22 | O | FPL 2S 2OP | 1 | | 20,349.00 | 20,349 | | |
| | | | | | | | | | GEN | O | GENERATOR | 1 | | 0.00 | | | |
| | | | | | | | | | | | | | | | | CONDITION ELEM | CD |
| | | | | | | | | | | | | | | | | EXTERIOR | A |
| | | | | | | | | | | | | | | | | INTERIOR | A |
| | | | | | | | | | | | | | | | | KITCHEN | A |
| | | | | | | | | | | | | | | | | BATHS | A |
| | | | | | | | | | | | | | | | | HEAT | A |
| | | | | | | | | | | | | | | | | ELECT | A |
| | | | | | | | | | | | | | | | | EFF.YR/AGE | 2003 / 19 |
| | | | | | | | | | | | | | | | | COND | 18 18 % |
| | | | | | | | | | | | | | | | | FUNC | 0 |
| | | | | | | | | | | | | | | | | ECON | 0 |
| | | | | | | | | | | | | | | | | DEPR | 19 % GD 81 |
| | | | | | | | | | | | | | | | | RCNLD | \$1,671,400 |