

Key: 6762

Town of SCITUATE - Fiscal Year 2024

10/18/2023 5:31 pm SEQ #: 6.458

LEGAL

LAND

DETACHED

BUILDING

CURRENT OWNER				PARCEL ID				LOCATION			
HUMPHREY JOOST & BRENNIA GORGONE 70 COBB LN SCITUATE, MA 02066				60-2A-2-0				70 COBB LN			
TRANSFER HISTORY				DOS	T	SALE PRICE	BK-PG (Cert)				
HUMPHREY JOOST & MCGOWAN BARBARA & WILLIAM				09/30/2016	QS	575,000	47544-203				
MCGOWAN WILLIAM R				08/06/2009	A	260,000	37569-326				
				01/01/1969	QS	26,000	3419-669				

CLASS	CLASS%	DESCRIPTION			BN ID	BN	CARD	
1010	100	SINGLE FAMILY				1	1 of 1	
PMT NO	PMT DT	TY	DESC	AMOUNT	INSP	BY	1st	%
20-100	02/11/2020	2	ADDITIONS	170,000	08/05/2020	JD	100	80
20-100	02/11/2020	2	ADDITIONS	170,000	03/23/2021	JD	100	100
89-345	07/05/1989	3	ALTERATIONS				100	100

CD	T	AC/SF/UN	Ngh	Inf1	Inf2	ADJ BASE	SAF	Inf3	Lpi	VC	CREDIT AMT	ADJ VALUE	
100	S	26,900	CLF 1.00	100	1.00	100	1.00	572,000	1.43	100	1.00	R06 1.30	503,530

TOTAL	26,900 SF	ZONING	FRNT	114	ASSESSED	CURRENT	PREVIOUS
Ngh	CLIFFS	NOTE	LAND	503,500	457,800		
Inf1	FACTOR 100		BUILDING	556,900	520,900		
Inf2	PHY 100		DETACHED	4,900	4,600		
			OTHER	0	0		
			TOTAL	1,065,300	983,300		

TY	QUAL	COND	DIM/NOTE	YB	UNITS	ADJ PRICE	RCNLD
SHF	A	1.00	30 0.70		20	17.03	200
HTB	A	1.00	10 0.90		1	5,181.80	4,700



BUILDING	CD	ADJ	DESC	MEASURE	8/5/2020	JD
MODEL	1		RESIDENTIAL	LIST	8/5/2020	EST
STYLE	5	1.00	COLONIAL [100%]	REVIEW	3/23/2021	JD
QUALITY	+	1.10	AVG +/GOOD - [100%]			
FRAME	1	1.00	WOOD FRAME [100%]			

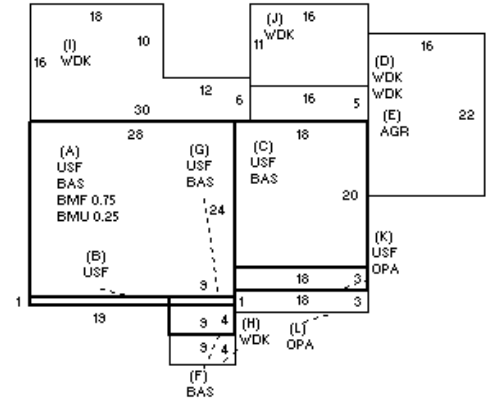

YEAR BLT	1968	SIZE ADJ	1.000	ELEMENT	CD	DESCRIPTION	ADJ	S	BAT	T	DESCRIPTION	UNITS	YB	ADJ PRICE	RCN	TOTAL RCN	598,798		
NET AREA	2,191	DETAIL ADJ	1.040	FOUNDATION	4	CONT BSMT WALL	1.00	A	BMU	N	BSMT UNFINISHED	168		59.09	9,928	CONDITION ELEM	CD		
\$NLA(RCN)	\$273	OVERALL	1.000	EXT COVER	1	WD SHINGLES	1.00	A	BMF	N	BSMT FINISH-SEP	504		82.95	41,808	EXTERIOR	V		
				ROOF SHAPE	1	GABLE	1.00	+	USF	L	UPPER STORY FIN	1,114	1968	206.37	229,891	INTERIOR	V		
				ROOF COVER	1	ASPH SHINGLES	1.00	+	BAS	L	BASE AREA	1,077	1968	226.93	244,400	KITCHEN	V		
				FLOOR COVER	34	COMB	1.00	+	WDK	N	WOOD DECK	732		42.24	30,920	BATHS	V		
				INT FINISH	1	PLASTER	1.00	E	AGR	N	ATT GARAGE	352		53.60	18,868	HEAT	U		
				HEATING/COOLING	11	HW/COOL AIR	1.04	+	OPA	N	OPEN PORCH	108		56.65	6,118	ELECT	U		
				FUEL SOURCE	1	OIL	1.00	F11	O	FPL 1S 1OP	1		8,009.10	8,009					
								ODS	O	OUT DOOR SHOWER	1		1,534.50	1,535					
																		EFF.YR/AGE	2015 / 7
																		COND	7 7 %
																		FUNC	0
																		ECON	0
																		DEPR	7 % GD 93
																		RCNLD	\$556,900