

Key: 6803

Town of SCITUATE - Fiscal Year 2024

10/18/2023 5:31 pm SEQ #: 6.500

LEGAL

LAND

DETACHED

BUILDING

CURRENT OWNER				PARCEL ID				LOCATION			
BROWNE MATTHEW D & HEIDI B 75 COBB LANE SCITUATE, MA 02066				60-2A-24-0				75 COBB LN			
TRANSFER HISTORY				DOS	T	SALE PRICE	BK-PG (Cert)				
BROWNE MATTHEW D & HEIDI				01/13/1999	QS	240,000	17045-218				
O'BRIEN NEIL E				10/17/1995	XX		13899-228				
O'BRIEN VIRGINIA J AND NE				08/04/1986	XX		7000-40				

CLASS	CLASS%	DESCRIPTION			BN ID	BN	CARD	
1010	100	SINGLE FAMILY				1	1 of 1	
PMT NO	PMT DT	TY	DESC	AMOUNT	INSP	BY	1st	%
04-721		3	ALTERATIONS		08/06/2007	SJ	100	100
		3	ALTERATIONS		08/31/2006	SJ	100	100
04-603	10/29/2004	3	ALTERATIONS	10,000	07/21/2005	SJ	100	100
	09/15/2004	3	ALTERATIONS	2,200	07/21/2005	SJ	100	100

TOTAL	22,521 SF	ZONING		FRNT	362	ASSESSED	CURRENT	PREVIOUS
Ngh	CLIFFS	NOTE				LAND	495,700	450,700
Inf1	FACTOR 100					BUILDING	496,600	448,000
Inf2	PHY 100					DETACHED	1,300	1,200
						OTHER	0	0
						TOTAL	993,600	899,900

TY	QUAL	COND	DIM/NOTE	YB	UNITS	ADJ PRICE	RCNLD
SHF	A	1.00 25 0.75	10 X 12	2005	120	13.93	1,300

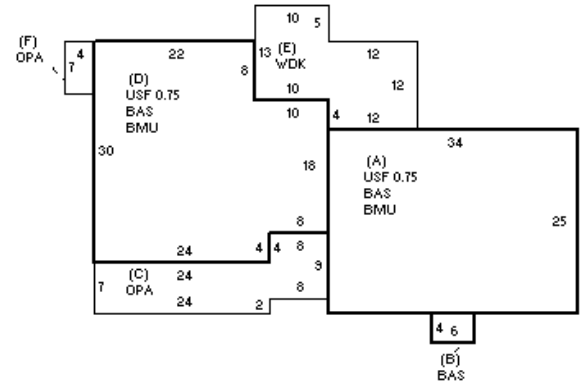

BLDG COMMENTS

BUILDING	CD	ADJ	DESC	MEASURE	10/13/2015	SJ
MODEL	1		RESIDENTIAL	LIST	10/13/2015	EST
STYLE	4	1.10	CAPE [100%]	REVIEW	3/14/2011	ER
QUALITY	A	1.00	AVERAGE [100%]			
FRAME	1	1.00	WOOD FRAME [100%]			

YEAR BLT	1965	SIZE ADJ	1.000	ELEMENT	CD	DESCRIPTION	ADJ	S	BAT	T	DESCRIPTION	UNITS	YB	ADJ PRICE	RCN	TOTAL RCN	719,709	
NET AREA	2,996	DETAIL ADJ	1.122	FOUNDATION	4	CONT BSMT WALL	1.00	+	BMU	N	BSMT UNFINISHED	1,698		41.59	70,628	CONDITION ELEM CD		
\$NLA(RCN)	\$240	OVERALL	1.000	EXT COVER	2	CLAPBOARD	1.00	A	USF	L	UPPER STORY FIN	638	1965	192.93	123,092	EXTERIOR		
CAPACITY			UNITS	ADJ	ROOF SHAPE	1	GABLE	1.00	+	BAS	L	BASE AREA	874	1965	212.16	185,425	INTERIOR	
STORIES	1.75	1.00	ROOF COVER	1	ASPH SHINGLES	1.00	+	OPA	N	OPEN PORCH	268		51.50	13,802	KITCHEN			
ROOMS	6	1.00	FLOOR COVER	14	COMB	1.00	D	BAS	L	BASE AREA	848	2006	212.16	179,909	BATHS			
BEDROOMS	2	1.00	INT FINISH	2	DRYWALL	1.00	D	USF	L	UPPER STORY FIN	636	2006	192.93	122,706	HEAT			
BATHROOMS	2	1.00	HEATING/COOLING	2	HOT WATER	1.02	E	WDK	N	WOOD DECK	274		38.40	10,522	ELECT			
# 1/2 BATHS	0	1.00	FUEL SOURCE	99	N/A	1.00		F21	O	FPL 2S 1OP	1		8,239.00	8,239				
TOT FIXTURES	6	\$5,386													EFF.YR/AGE 1972 / 50			
# UNITS	1	1.00													COND 31 31 %			
															FUNC 0			
															ECON 0			
															DEPR 31 % GD 69			
															RCNLD \$496,600			