

Key: 6824

Town of SCITUATE - Fiscal Year 2024

10/18/2023 5:31 pm SEQ #: 6.521

LEGAL

CURRENT OWNER				PARCEL ID				LOCATION			
WOOD CHARLES B & JEAN 30 FOXWELL LANE SCITUATE, MA 02066				60-2A-18-0				30 FOXWELL LN			
TRANSFER HISTORY				DOS	T	SALE PRICE		BK-PG (Cert)			
WOOD CHARLES B & JEAN				01/01/1972	QS			3678-437			
BLANCHARD EUGENE AND JANE				01/01/1955	XX			2331-56			

CLASS	CLASS%	DESCRIPTION			BN ID	BN	CARD	
1010	100	SINGLE FAMILY				1	1 of 1	
PMT NO	PMT DT	TY	DESC	AMOUNT	INSP	BY	1st	%
12-180	04/09/2012	3	ALTERATIONS	3,000	08/30/2012	SJ	100	100
10-109	04/02/2010	3	ALTERATIONS	2,000	08/31/2010	SJ	100	100
97-369	09/01/1997	3	ALTERATIONS				100	100

LAND

CD	T	AC/SF/UN	Ngh	Infl1	Infl2	ADJ BASE	SAF	Infl3	Lpi	VC	CREDIT AMT	ADJ VALUE
100	S	40,000	CLF 1.00	100	1.00	572,000	1.00	100	1.00	R06	1.30	525,250
300	A	0.046	CLF 1.00	100	1.00	25,740	1.00	100	1.00	R06	1.30	1,180

TOTAL	41,992 SF	ZONING	FRNT	115	ASSESSED	CURRENT	PREVIOUS
Ngh	CLIFFS	NOTE			LAND	526,400	478,600
Infl1	FACTOR 100		BUILDING	210,200	189,400		
Infl2	PHY 100		DETACHED	10,300	9,800		
			OTHER	0	0		
			TOTAL		746,900	677,800	

DETACHED

TY	QUAL	COND	DIM/NOTE	YB	UNITS	ADJ PRICE	RCNLD
DGF	A	1.00	60 0.40		576	44.24	10,200
SHF	A	1.00	30 0.70		10	17.03	100

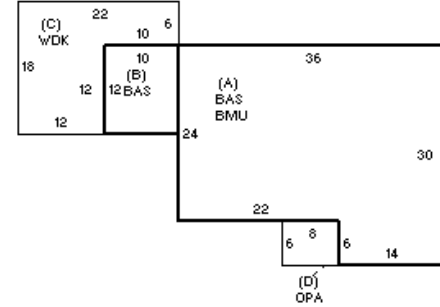

BUILDING	CD	ADJ	DESC	MEASURE	10/2/2009	PL
MODEL	1		RESIDENTIAL	LIST	10/2/2009	EST
STYLE	1	0.85	RANCH [100%]	REVIEW	3/14/2011	ER
QUALITY	A	1.00	AVERAGE [100%]			
FRAME	1	1.00	WOOD FRAME [100%]			

BLDG COMMENTS

BUILDING

YEAR BLT	1965	SIZE ADJ	1.000	ELEMENT	CD	DESCRIPTION	ADJ	S	BAT	T	DESCRIPTION	UNITS	YB	ADJ PRICE	RCN	TOTAL RCN	280,223
NET AREA	1,068	DETAIL ADJ	0.850	FOUNDATION	4	CONT BSMT WALL	1.00	A	BMU	N	BSMT UNFINISHED	948		47.91	45,418		
\$NLA(RCN)	\$262	OVERALL	1.000	EXT COVER	1	WD SHINGLES	1.00	+	BAS	L	BASE AREA	1,068	1965	198.89	212,414		
				ROOF SHAPE	1	GABLE	1.00	C	WDK	N	WOOD DECK	276		38.40	10,598		
				ROOF COVER	1	ASPH SHINGLES	1.00	D	OPA	N	OPEN PORCH	48		51.50	2,472		
				FLOOR COVER	34	COMB	1.00		F11	O	FPL 1S 1OP	1		7,281.00	7,281		
				INT FINISH	1	PLASTER	1.00										
				HEATING/COOLING	1	FORCED AIR	1.00										
				FUEL SOURCE	99	N/A	1.00										
																CONDITION ELEM	CD
																EXTERIOR	
																INTERIOR	
																KITCHEN	
																BATHS	
																HEAT	
																ELECT	
																EFF.YR/AGE	1990 / 32
																COND	25 25 %
																FUNC	0
																ECON	0
																DEPR	25 % GD 75
																RCNLD	\$210,200