

Key: 6841

Town of SCITUATE - Fiscal Year 2024

10/18/2023 5:31 pm SEQ #: 6.535

LEGAL

CURRENT OWNER				PARCEL ID				LOCATION				
GRYBAUSKAS JOHN K & JENNIFER E 15 MOORS CIR SCITUATE, MA 02066				62-1-1-R				15 MOORS CIR				
TRANSFER HISTORY				DOS	T	SALE PRICE	BK-PG (Cert)					
GRYBAUSKAS JOHN K & JENNI				07/02/2007	QS	950,000	34761-31					
MCLAUGHLIN EDWARD				06/29/2004	O	275,000	28549-263					
PRIESTLEY SUSAN E				09/21/1999	G2	599,900	17880-247					
CD	T	AC/SF/UN	Ngh	Inf1	Inf2	ADJ BASE	SAF	Inf3	Lpi	VC	CREDIT AMT	ADJ VALUE
100	S	40,000	GB 1.00	100	1.00	440,000	1.00	100	1.00	R05	1.00	404,040
300	A	0.202	GB 1.00	100	1.00	19,800	1.00	100	1.00	R05	1.00	4,000

LAND

TOTAL	1.121 Acres	ZONING	FRNT	100	ASSESSED	CURRENT	PREVIOUS
Ngh	GREENBUSH	NOTE			LAND	408,000	371,200
Inf1	FACTOR 100		BUILDING	1,049,900	913,900		
Inf2	PHY 100		DETACHED	0	0		
			OTHER	0	0		
			<b>TOTAL</b>		<b>1,457,900</b>	<b>1,285,100</b>	

DETACHED

TY	QUAL	COND	DIM/NOTE	YB	UNITS	ADJ PRICE	RCNLD



BUILDING	CD	ADJ	DESC	MEASURE	4/27/2015	SJ
MODEL	1		RESIDENTIAL	LIST	4/27/2015	EST
STYLE	5	1.00	COLONIAL [100%]	REVIEW	3/14/2011	ER
QUALITY	V	1.40	VERY GOOD [100%]			
FRAME	1	1.00	WOOD FRAME [100%]			

BUILDING

YEAR BLT	2005	SIZE ADJ	1.000	ELEMENT	CD	DESCRIPTION	ADJ
NET AREA	3,958	DETAIL ADJ	1.030	FOUNDATION	4	CONT BSMT WALL	1.00
\$NLA(RCN)	\$316	OVERALL	1.000	EXT COVER	2	CLAPBOARD	1.00
				ROOF SHAPE	1	GABLE	1.00
				ROOF COVER	1	ASPH SHINGLES	1.00
				FLOOR COVER	13	COMB	1.00
				INT FINISH	2	DRYWALL	1.00
				HEATING/COOLING	9	WARM/COOL AIR	1.03
				FUEL SOURCE	99	N/A	1.00

S	BAT	T	DESCRIPTION	UNITS	YB	ADJ PRICE	RCN
+	BMU	N	BSMT UNFINISHED	1,166		57.58	67,144
+	BMF	N	BSMT FINISH-SEP	640		80.84	51,736
+	USF	L	UPPER STORY FIN	2,142	2005	240.22	514,549
+	ATU	N	ATTIC UNF	640		51.80	33,152
+	OPA	N	OPEN PORCH	472		72.10	34,031
+	BIG	N	BUILT-IN GARAGE	676		59.46	40,194
+	WDK	N	WOOD DECK	310		53.76	16,666
+	BAS	L	BASE AREA	1,816	2005	264.15	479,702

YEAR BLT	2005	SIZE ADJ	1.000	TOTAL RCN	1,249,863
NET AREA	3,958	DETAIL ADJ	1.030	CONDITION ELEM	CD
\$NLA(RCN)	\$316	OVERALL	1.000	EXTERIOR	
				INTERIOR	
				KITCHEN	
				BATHS	
				HEAT	
				ELECT	

CLASS	CLASS%	DESCRIPTION			BN ID	BN	CARD	
1010	100	SINGLE FAMILY				1	1 of 1	
PMT NO	PMT DT	TY	DESC	AMOUNT	INSP	BY	1st	%
17-201	04/12/2017	3	ALTERATIONS	25,000	08/23/2017	SJ	100	100
11-651	10/18/2011	3	ALTERATIONS	856	08/31/2012	SJ	100	100
		7	OTHERS		04/05/2009	SJ	100	100
		1	NEW CONST		09/05/2006	SJ	100	100
		1	NEW CONST		07/18/2005	SJ	100	100

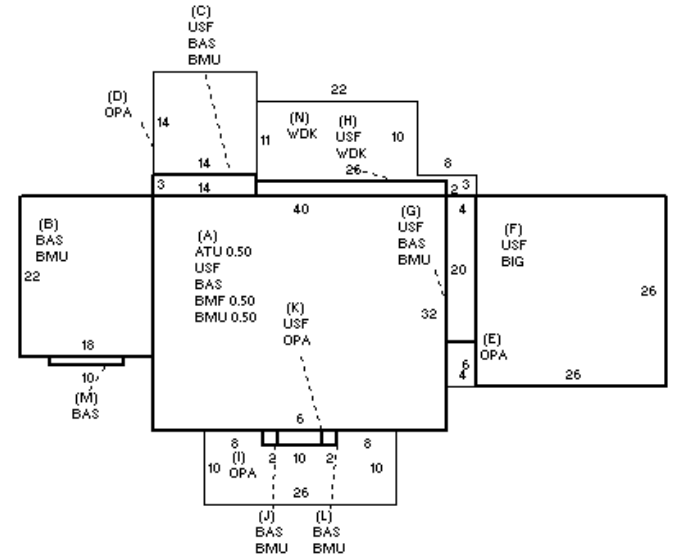

EFF.YR/AGE	2006 / 16	
COND	16	16 %
FUNC	0	
ECON	0	
DEPR	16	% GD 84
RCNLD	\$1,049,900	