

Key: 6911

Town of SCITUATE - Fiscal Year 2024

10/18/2023 5:31 pm SEQ #: 6.605

LEGAL

LAND

DETACHED

BUILDING

CURRENT OWNER				PARCEL ID				LOCATION			
WITTRUP ALAN SCOTT 47 COLLIER RD SCITUATE, MA 02066				64-6-13-0				47 COLLIER RD			
TRANSFER HISTORY				DOS	T	SALE PRICE	BK-PG (Cert)				
WITTRUP ALAN SCOTT				11/22/2021	F	100	56057-7				
WITTRUP RICHARD & MARILYN				09/29/2011	F	10	40380-222				
WITTRUP MARILYN E & RICHA				03/24/2003	F	100	24573-313				

CLASS	CLASS%	DESCRIPTION			BN ID	BN	CARD	
1010	100	SINGLE FAMILY				1	1 of 1	
PMT NO	PMT DT	TY	DESC	AMOUNT	INSP	BY	1st	%
90-676	11/01/1990	3	OTHERS		07/06/2023	JD	100	100
90-409	07/16/1990	3	ALTERATIONS				100	100
90-269	05/29/1990	3	ALTERATIONS				100	100
89-518	09/18/1989	3	ALTERATIONS				100	100

CD	T	AC/SF/UN	Ngh	Inf1	Inf2	ADJ BASE	SAF	Inf3	Lpi	VC	CREDIT AMT	ADJ VALUE	
100	S	5,000	CLF	1.00	100	1.00	1.00	1,672,000	6.92	100	1.00	WF3 3.80	1,327,970

TOTAL	5,009 SF	ZONING	FRNT	53	ASSESSED	CURRENT	PREVIOUS
Ngh	CLIFFS	NOTE	LAND	1,328,000	1,207,200		
Inf1	FACTOR 100		BUILDING	244,400	120,500		
Inf2	PHY 100		DETACHED	0	2,800		
			OTHER	0	0		
			TOTAL	1,572,400	1,330,500		

TY	QUAL	COND	DIM/NOTE	YB	UNITS	ADJ PRICE	RCNLD



BLDG COMMENTS

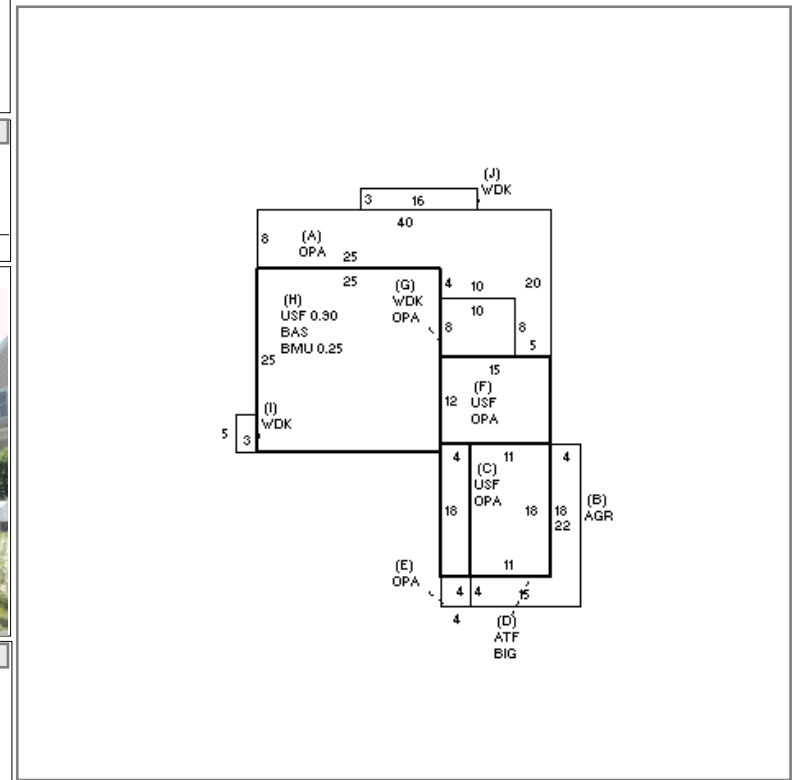

BUILDING	CD	ADJ	DESC	MEASURE	7/6/2023	JD
MODEL	1		RESIDENTIAL	LIST	7/6/2023	EST
STYLE	7	1.20	CONVENTIONAL [100%]	REVIEW	3/14/2011	ER
QUALITY	A	1.00	AVERAGE [100%]			
FRAME	1	1.00	WOOD FRAME [100%]			

YEAR BLT	1916	SIZE ADJ	1.000	ELEMENT	CD	DESCRIPTION	ADJ	S	BAT	T	DESCRIPTION	UNITS	YB	ADJ PRICE	RCN
NET AREA	1,638	DETAIL ADJ	1.176	FOUNDATION	1	PIER	0.98	+	OPA	N	OPEN PORCH	768		51.50	39,552
\$NLA(RCN)	\$276	OVERALL	1.000	EXT COVER	1	WD SHINGLES	1.00	B	AGR	N	ATT GARAGE	132		49.79	6,572
				ROOF SHAPE	1	GABLE	1.00	+	USF	L	UPPER STORY FIN	815	1916	224.31	182,814
				ROOF COVER	1	ASPH SHINGLES	1.00	D	BIG	N	BUILT-IN GARAGE	198		58.55	11,593
				FLOOR COVER	2	SOFTWOOD	1.00	D	ATF	L	ATTIC FINISH	198	1916	159.37	31,555
				INT FINISH	1	PLASTER	1.00	H	BMU	N	BSMT UNFINISHED	156		63.15	9,851
				HEATING/COOLING	1	FORCED AIR	1.00	H	BAS	L	BASE AREA	625	1916	246.66	154,163
				FUEL SOURCE	2	GAS	1.00	+	WDK	N	WOOD DECK	143		38.40	5,491
									F21	O	FPL 2S 1OP	1		8,239.00	8,239
									GEN	O	GENERATOR	1		0.00	

TOTAL RCN	452,652
CONDITION ELEM	CD
EXTERIOR	F
INTERIOR	F
KITCHEN	F
BATHS	F
HEAT	O
ELECT	A
EFF.YR/AGE	1961 / 61
COND	46 46%
FUNC	0
ECON	0
DEPR	46 % GD 54
RCNLD	\$244,400