

Key: 6914

Town of SCITUATE - Fiscal Year 2024

10/18/2023 5:31 pm SEQ #: 6.608

LEGAL

LAND

DETACHED

BUILDING

CURRENT OWNER				PARCEL ID				LOCATION				
CUBELLIS LENORD G TR & VIRGINIA M TR 55 COLLIER RD SCITUATE, MA 02066				64-6-16-0				55 COLLIER RD				
TRANSFER HISTORY				DOS	T	SALE PRICE	BK-PG (Cert)					
CUBELLIS LENORD G TR & VIRGINIA M TR				01/26/2017	F	1	48044-344					
CUBELLIS LENORD & VIRGINIA M TR				11/26/2013	QS	950,000	43861-90					
MASTRANGELO WILLIAM C				08/14/1992	QS	288,500	11186-297					
CD	T	AC/SF/UN	Ngh	Inf1	Inf2	ADJ BASE	SAF	Inf3	Lpi	VC	CREDIT AMT	ADJ VALUE
100	S	7,500 CLF	1.00	100	1.00	1,672,000	4.70	100	1.00	WF3	3.80	1,352,480

CLASS	CLASS%	DESCRIPTION			BN ID	BN	CARD	
1010	100	SINGLE FAMILY				1	1 of 1	
PMT NO	PMT DT	TY	DESC	AMOUNT	INSP	BY	1st	%
19-139	03/05/2019	2	ADDITIONS	79,500	08/28/2019	JD	100	50
19-139	03/05/2019	2	ADDITIONS	79,500	08/06/2020	JD	100	100
14-198	04/22/2014	2	ADDITIONS	140,000	09/30/2014	RJM	100	100
14-198	04/22/2014	2	ADDITIONS	140,000	08/24/2015	SJ	100	100
94-367	08/04/1994	3	ALTERATIONS				100	100

TOTAL	7,500 SF	ZONING	FRNT	55	ASSESSED	CURRENT	PREVIOUS
Ngh	CLIFFS	NOTE			LAND	1,352,500	1,229,500
Inf1	FACTOR 100		BUILDING	760,000	675,900		
Inf2	PHY 100		DETACHED	0	0		
			OTHER	0	0		
					TOTAL	2,112,500	1,905,400

TY	QUAL	COND	DIM/NOTE	YB	UNITS	ADJ PRICE	RCNLD	PHOTO
								08/06/2020



BUILDING	CD	ADJ	DESC	MEASURE	8/28/2019	JD
MODEL	1		RESIDENTIAL	LIST	8/28/2019	JD
STYLE	7	1.20	CONVENTIONAL [100%]	REVIEW	8/6/2020	JD
QUALITY	G	1.20	GOOD [100%]			
FRAME	1	1.00	WOOD FRAME [100%]			

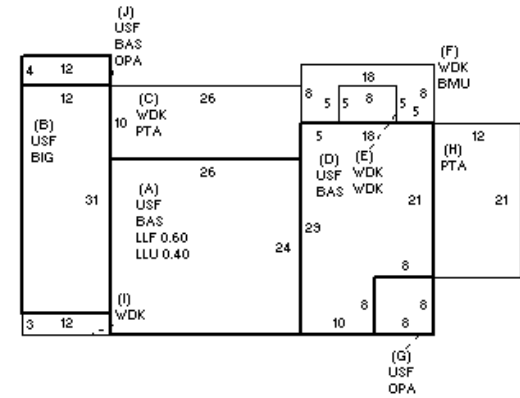

BLDG COMMENTS

YEAR BLT	1928	SIZE ADJ	1.000	ELEMENT	CD	DESCRIPTION	ADJ	S	BAT	T	DESCRIPTION	UNITS	YB	ADJ PRICE	RCN	TOTAL RCN	904,769
NET AREA	3,070	DETAIL ADJ	1.260	FOUNDATION	4	CONT BSMT WALL	1.00	A	LLU	N	LOWER LEVEL UNF	250		81.98	20,496	CONDITION ELEM	CD
\$NLA(RCN)	\$295	OVERALL	1.000	EXT COVER	1	WD SHINGLES	1.00	A	LLF	L	LOWER LEVEL FIN	374	1928	194.78	72,848	EXTERIOR	G
				ROOF SHAPE	1	GABLE	1.00	+	USF	L	UPPER STORY FIN	1,566	1928	256.81	402,161	INTERIOR	G
				ROOF COVER	2	WOOD SHINGLES	1.01	B	BIG	N	BUILT-IN GARAGE	372		72.41	26,938	KITCHEN	V
				FLOOR COVER	12	COMB	1.00	+	PTA	N	PATIO	512		17.88	9,155	BATHS	V
				INT FINISH	1	PLASTER	1.00	+	BAS	L	BASE AREA	1,130	1928	282.39	319,105	HEAT	U
				HEATING/COOLING	11	HW/COOL AIR	1.04	+	WDK	N	WOOD DECK	480		46.08	22,118	ELECT	U
				FUEL SOURCE	2	GAS	1.00	F	BMU	N	BSMT UNFINISHED	104		75.78	7,882		
								+	OPA	N	OPEN PORCH	112		61.80	6,922		
								F21	O	FPL 2S 1OP	1		9,886.80	9,887			
								GEN	O	GENERATOR	1		0.00				
												EFF.YR/AGE	2006 / 16				
												COND	16 16 %				
												FUNC	0				
												ECON	0				
												DEPR	16 % GD		84		
												RCNLD			\$760,000		