

Key: 7129

Town of SCITUATE - Fiscal Year 2024

10/18/2023 5:31 pm SEQ #: 6.812

LEGAL

CURRENT OWNER				PARCEL ID				LOCATION			
GARON THERESA A TR 47 KENNETH RD SCITUATE, MA 02066				40-11-24-0				47 KENNETH RD			
TRANSFER HISTORY				DOS	T	SALE PRICE	BK-PG (Cert)				
GARON THERESA A TR				10/11/2019	F	100	(129278)				
GARON ROBERT A & TERESA A				08/24/1992	F	100	(83442)				
GARON ROBERT A & GILL TER				01/01/1990	QS	-					

CLASS	CLASS%	DESCRIPTION			BN ID	BN	CARD	
1010	100	SINGLE FAMILY				1	1 of 1	
PMT NO	PMT DT	TY	DESC	AMOUNT	INSP	BY	1st	%
05-850	12/22/2005	2	ADDITIONS	80,000	09/12/2006	SJ	100	100
03-008	01/07/2003	3	ALTERATIONS				100	100
01-238	06/01/2001	3	ALTERATIONS				100	100
93-295	06/01/1993	3	ALTERATIONS				100	100

LAND

CD	T	AC/SF/UN	Ngh	Inf1	Inf2	ADJ BASE	SAF	Inf3	Lpi	VC	CREDIT AMT	ADJ VALUE	
100	S	10,000	OS 1.00	100	1.00	100	1.00	440,000	3.58	100	1.00	R08 1.00	361,190

TOTAL	10,019 SF	ZONING	FRNT	51	ASSESSED	CURRENT	PREVIOUS
Ngh	OCEANSIDE	N O T E  IN M39- C/W 23A	LAND	361,200	328,400		
Inf1	FACTOR 100		BUILDING	361,500	321,700		
Inf2	PHY 100		DETACHED	500	500		
			OTHER	0	0		
			TOTAL	723,200	650,600		

DETACHED

TY	QUAL	COND	DIM/NOTE	YB	UNITS	ADJ PRICE	RCNLD	PHOTO	10/17/2003
SHF	A	1.00	30 0.70		40	17.03	500		

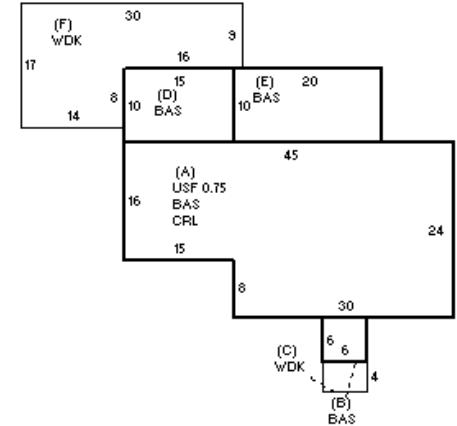

BUILDING

BUILDING	CD	ADJ	DESC	MEASURE	4/28/2015	SJ
MODEL	1		RESIDENTIAL	LIST	4/28/2015	EST
STYLE	4	1.10	CAPE [100%]	REVIEW	3/10/2011	ER
QUALITY	A	1.00	AVERAGE [100%]			
FRAME	1	1.00	WOOD FRAME [100%]			

BLDG COMMENTS		

YEAR BLT	1951	SIZE ADJ	1.000	ELEMENT	CD	DESCRIPTION	ADJ	S	BAT	T	DESCRIPTION	UNITS	YB	ADJ PRICE	RCN	TOTAL RCN	488,568													
NET AREA	2,066	DETAIL ADJ	1.122	FOUNDATION	4	CONT BSMT WALL	1.00	A	CRL	N	BSMT CRAWL	960		10.65	10,224															
\$NLA(RCN)	\$236	OVERALL	1.000	EXT COVER	2	CLAPBOARD	1.00	A	USF	L	UPPER STORY FIN	720	1951	204.33	147,120															
				ROOF SHAPE	1	GABLE	1.00	+	BAS	L	BASE AREA	1,146	1951	224.69	257,497															
				ROOF COVER	1	ASPH SHINGLES	1.00	+	WDK	N	WOOD DECK	406		38.40	15,590															
				FLOOR COVER	14	COMB	1.00	E	BAS	L	BASE AREA	200	2006	224.69	44,938															
				INT FINISH	1	PLASTER	1.00		FPL	O	FIREPLACE	1		7,813.00	7,813															
				HEATING/COOLING	2	HOT WATER	1.02																							
				FUEL SOURCE	99	N/A	1.00																							
<table border="1"> <thead> <tr> <th>CONDITION ELEM</th> <th>CD</th> </tr> </thead> <tbody> <tr> <td>EXTERIOR</td> <td></td> </tr> <tr> <td>INTERIOR</td> <td></td> </tr> <tr> <td>KITCHEN</td> <td></td> </tr> <tr> <td>BATHS</td> <td></td> </tr> <tr> <td>HEAT</td> <td></td> </tr> <tr> <td>ELECT</td> <td></td> </tr> </tbody> </table>																CONDITION ELEM	CD	EXTERIOR		INTERIOR		KITCHEN		BATHS		HEAT		ELECT		
CONDITION ELEM	CD																													
EXTERIOR																														
INTERIOR																														
KITCHEN																														
BATHS																														
HEAT																														
ELECT																														
<table border="1"> <thead> <tr> <th>EFF.YR/AGE</th> <td colspan="2">1985 / 37</td> </tr> </thead> <tbody> <tr> <td>COND</td> <td>26</td> <td>26 %</td> </tr> <tr> <td>FUNC</td> <td>0</td> <td></td> </tr> <tr> <td>ECON</td> <td>0</td> <td></td> </tr> <tr> <td>DEPR</td> <td>26</td> <td>% GD 74</td> </tr> </tbody> </table>																EFF.YR/AGE	1985 / 37		COND	26	26 %	FUNC	0		ECON	0		DEPR	26	% GD 74
EFF.YR/AGE	1985 / 37																													
COND	26	26 %																												
FUNC	0																													
ECON	0																													
DEPR	26	% GD 74																												
<table border="1"> <thead> <tr> <th>RCNLD</th> <td>\$361,500</td> </tr> </thead> </table>																RCNLD	\$361,500													
RCNLD	\$361,500																													