

Key: 7290

Town of SCITUATE - Fiscal Year 2024

10/18/2023 5:31 pm SEQ #: 6.967

LEGALS

CURRENT OWNER				PARCEL ID				LOCATION			
LYNCH DENISE E				71-14-3-0				93-REAR CENTRAL AV			
S/O LYNCH DENISE E TR				TRANSFER HISTORY				DOS	T	SALE PRICE	BK-PG (Cert)
73 ARROWWOOD DR				LYNCH DENISE E TR				03/22/2023	F	100	57761-302
SCITUATE, MA 02066				LYNCH DENISE E				10/06/2016	F	1	47564-218
				GALLINELLI MAUDE F				07/02/1999	F	1	17637-77

CLASS	CLASS%	DESCRIPTION			BN ID	BN	CARD	
1010	100	SINGLE FAMILY				1	1 of 1	
PMT NO	PMT DT	TY	DESC	AMOUNT	INSP	BY	1st	%
	09/06/2022	7	OTHERS		10/11/2022	JD	100	99
		7	OTHERS				100	100

LAND

CD	T	AC/SF/UN	Ngh	Infl1	Infl2	ADJ BASE	SAF	Infl3	Lpi	VC	CREDIT AMT	ADJ VALUE
100	S	40,000	HUM 1.00	100	1.00	638,000	1.00	100	1.00	RF2	1.45	585,860
300	A	0.732	HUM 1.00	100	1.00	28,710	1.00	100	1.00	RF2	1.45	21,020

TOTAL	1.650 Acres	ZONING	FRNT	135	ASSESSED	CURRENT	PREVIOUS
Ngh	HUMAROCK	N O T E C/W 71-14-2	LAND	606,900	552,800		
Infl1	FACTOR 100		BUILDING	566,300	488,800		
Infl2	PHY 100		DETACHED	1,700	20,100		
			OTHER	0	0		
			TOTAL	1,174,900	1,061,700		

DETACHED

TY	QUAL	COND	DIM/NOTE	YB	UNITS	ADJ PRICE	RCNLD
SHF	A	1.00	30 0.70 12X16		192	12.38	1,700

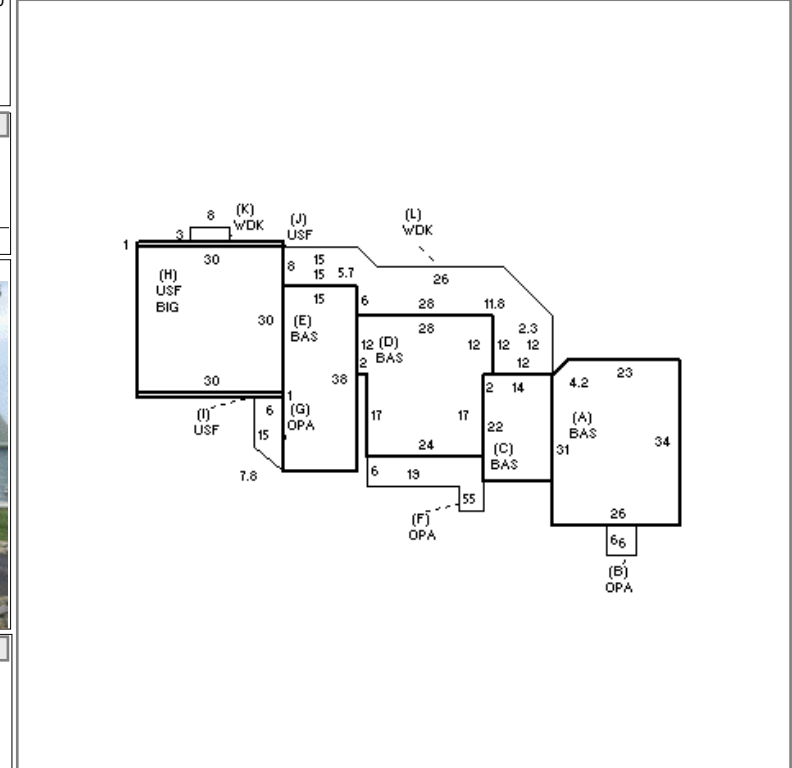

BUILDING	CD	ADJ	DESC	MEASURE	10/11/2022	JD
MODEL	1		RESIDENTIAL	LIST	10/11/2022	EST
STYLE	4	1.10	CAPE [100%]	REVIEW	6/12/2023	JD
QUALITY	+	1.10	AVG +/GOOD - [100%]			
FRAME	1	1.00	WOOD FRAME [100%]			

BLDG COMMENTS

BUILDING

YEAR BLT	1949	SIZE ADJ	1.000	ELEMENT	CD	DESCRIPTION	ADJ	S	BAT	T	DESCRIPTION	UNITS	YB	ADJ PRICE	RCN	TOTAL RCN	884,886		
NET AREA	3,462	DETAIL ADJ	1.144	FOUNDATION	4	CONT BSMT WALL	1.00	+	BAS	L	BASE AREA	2,502	1949	233.97	585,390	CONDITION ELEM	CD		
\$NLA(RCN)	\$256	OVERALL	1.000	EXT COVER	2	CLAPBOARD	1.00	+	OPA	N	OPEN PORCH	280		56.65	15,862	EXTERIOR	A		
				ROOF SHAPE	1	GABLE	1.00	H	BIG	N	BUILT-IN GARAGE	900		49.34	44,402	INTERIOR	A		
				ROOF COVER	2	WOOD SHINGLES	1.01	+	USF	L	UPPER STORY FIN	960	1949	212.77	204,259	KITCHEN	A		
				FLOOR COVER	2	SOFTWOOD	1.00	+	WDK	N	WOOD DECK	645		42.24	27,245	BATHS	A		
				INT FINISH	1	PLASTER	1.00	GEN	O	GENERATOR	1			0.00		HEAT	A		
				HEATING/COOLING	9	WARM/COOL AIR	1.03	ODS	O	OUT DOOR SHOWER	1			1,688.50	1,689	ELECT	A		
				FUEL SOURCE	1	OIL	1.00												
																		EFF.YR/AGE	1968 / 54
																		COND	36 36 %
																		FUNC	0
																		ECON	0
																		DEPR	36 % GD 64
																		RCNLD	\$566,300