

Key: 7369

Town of SCITUATE - Fiscal Year 2024

10/18/2023 5:31 pm SEQ #: 7.045

LEGAL LAND

CURRENT OWNER				PARCEL ID				LOCATION					
CLARK BARBARA E & MCCOURT SUSAN CLARK C/O BARBARA CLARK 78 BARBARA RD WALTHAM, MA 02453				71-6-11-0				127 HUMAROCK BEACH					
TRANSFER HISTORY				DOS	T	SALE PRICE	BK-PG (Cert)						
CLARK BARBARA E & CLARK BE MCCOURT SC				07/01/2016	F	100	47134-199						
ESTATE OF ARTHUR J CLARK				10/19/1993	F	1	12302-96						
				01/01/1957	XX		2494-47						
CD	T	AC/SF/UN	Ngh	Inf1	Inf2	ADJ BASE	SAF	Inf3	Lpi	VC	CREDIT AMT	ADJ VALUE	
100	S	7,500	HUM 1.00	100	1.00	100	1.00	748,000	4.70	100	1.00	WF7 1.70	605,060

CLASS	CLASS%	DESCRIPTION			BN ID	BN	CARD	
1010	100	SINGLE FAMILY				1	1 of 1	
PMT NO	PMT DT	TY	DESC	AMOUNT	INSP	BY	1st	%
91-667	11/01/1991	3	ALTERATIONS				100	100

LEGAL LAND

TOTAL	7,492 SF	ZONING	FRNT	50	ASSESSED	CURRENT	PREVIOUS
Ngh	HUMAROCK	NOTE			LAND	605,100	517,700
Inf1	FACTOR 100		BUILDING	120,000	113,500		
Inf2	PHY 100		DETACHED	11,200	10,700		
			OTHER	0	0		
TOTAL					736,300	641,900	

TY	QUAL	COND	DIM/NOTE	YB	UNITS	ADJ PRICE	RCNLD
DGF	-	0.90	40 0.60		432	43.24	11,200

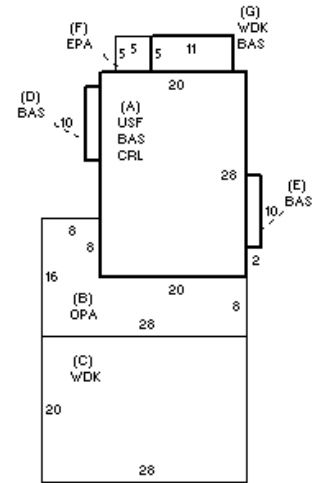

DETACHED

BUILDING	CD	ADJ	DESC	MEASURE	4/8/2010	PL
MODEL	1		RESIDENTIAL	LIST	4/8/2010	EST
STYLE	7	1.20	CONVENTIONAL [100%]	REVIEW	3/9/2011	ER
QUALITY	A	1.00	AVERAGE [100%]			
FRAME	1	1.00	WOOD FRAME [100%]			

BLDG COMMENTS
FY12 FR- COLONIAL TO CONV

BUILDING

YEAR BLT	1920	SIZE ADJ	1.000	ELEMENT	CD	DESCRIPTION	ADJ	S	BAT	T	DESCRIPTION	UNITS	YB	ADJ PRICE	RCN	TOTAL RCN	375,126												
NET AREA	1,215	DETAIL ADJ	1.200	FOUNDATION	4	CONT BSMT WALL	1.00	A	CRL	N	BSMT CRAWL	560		12.89	7,217														
\$NLA(RCN)	\$309	OVERALL	1.000	EXT COVER	1	WD SHINGLES	1.00	A	USF	L	UPPER STORY FIN	560	1920	246.14	137,840														
				ROOF SHAPE	2	HIP	1.00	B	OPA	N	OPEN PORCH	288		51.50	14,832														
				ROOF COVER	1	ASPH SHINGLES	1.00	+	WDK	N	WOOD DECK	615		38.40	23,616														
				FLOOR COVER	2	SOFTWOOD	1.00	+	BAS	L	BASE AREA	655	1920	270.67	177,287														
				INT FINISH	1	PLASTER	1.00	F	EPA	N	ENCLOSED PORCH	25		90.20	2,255														
				HEATING/COOLING	99	N/A	1.00	F21	O		FPL 2S 1OP	1		8,239.00	8,239														
				FUEL SOURCE	99	N/A	1.00																						
<table border="1"> <thead> <tr> <th>CONDITION ELEM</th> <th>CD</th> </tr> </thead> <tbody> <tr> <td>EXTERIOR</td> <td></td> </tr> <tr> <td>INTERIOR</td> <td></td> </tr> <tr> <td>KITCHEN</td> <td></td> </tr> <tr> <td>BATHS</td> <td></td> </tr> <tr> <td>HEAT</td> <td></td> </tr> <tr> <td>ELECT</td> <td></td> </tr> </tbody> </table>																CONDITION ELEM	CD	EXTERIOR		INTERIOR		KITCHEN		BATHS		HEAT		ELECT	
CONDITION ELEM	CD																												
EXTERIOR																													
INTERIOR																													
KITCHEN																													
BATHS																													
HEAT																													
ELECT																													
<table border="1"> <thead> <tr> <th>EFF.YR/AGE</th> <td>1952 / 70</td> </tr> </thead> <tbody> <tr> <td>COND</td> <td>64 64 %</td> </tr> <tr> <td>FUNC</td> <td>4 PARTIAL HEAT</td> </tr> <tr> <td>ECON</td> <td>0</td> </tr> <tr> <td>DEPR</td> <td>68 % GD 32</td> </tr> </tbody> </table>																EFF.YR/AGE	1952 / 70	COND	64 64 %	FUNC	4 PARTIAL HEAT	ECON	0	DEPR	68 % GD 32				
EFF.YR/AGE	1952 / 70																												
COND	64 64 %																												
FUNC	4 PARTIAL HEAT																												
ECON	0																												
DEPR	68 % GD 32																												
<table border="1"> <thead> <tr> <th>RCNLD</th> <td>\$120,000</td> </tr> </thead> </table>																RCNLD	\$120,000												
RCNLD	\$120,000																												