

Key: 7523

Town of SCITUATE - Fiscal Year 2024

10/18/2023 5:31 pm SEQ #: 7.197

LEGAL

CURRENT OWNER				PARCEL ID				LOCATION			
DORAN MARTA KATHERINE 59 AMHERST ROAD WABAN, MA 02468				68-4-2-0				38 CLIFF ROAD SOUTH			
TRANSFER HISTORY				DOS	T	SALE PRICE	BK-PG (Cert)				
DORAN MARTA KATHERINE				11/15/2019	F	100	(129462)				
DORAN FRANCIS M JR &				08/01/2001	F		(99708)				
DORAN FRANCIS JR TRUSTEE				12/27/1989	XX		(C00079545)				

CLASS	CLASS%	DESCRIPTION			BN ID	BN	CARD	
1010	100	SINGLE FAMILY				1	1 of 1	
PMT NO	PMT DT	TY	DESC	AMOUNT	INSP	BY	1st	%
06-738	12/01/2006	3	ALTERATIONS	8,900	09/10/2007	SJ	100	100
		6	CYCL GROWTH				100	100

LAND

CD	T	AC/SF/UN	Ngh	Inf1	Inf2	ADJ BASE	SAF	Inf3	Lpi	VC	CREDIT AMT	ADJ VALUE
100	S	5,864	HUM	1.00	100	1.00	100	1.00	WF7	1.70		598,210

TOTAL	5,864 SF	ZONING		FRNT	58	ASSESSED	CURRENT	PREVIOUS
Ngh	HUMAROCK	NOTE		LAND	598,200	511,800		
Inf1	FACTOR 100		BUILDING	242,600	219,200			
Inf2	PHY 100		DETACHED	0	0			
			OTHER	0	0			
				TOTAL	840,800	731,000		

DETACHED

TY	QUAL	COND	DIM/NOTE	YB	UNITS	ADJ PRICE	RCNLD

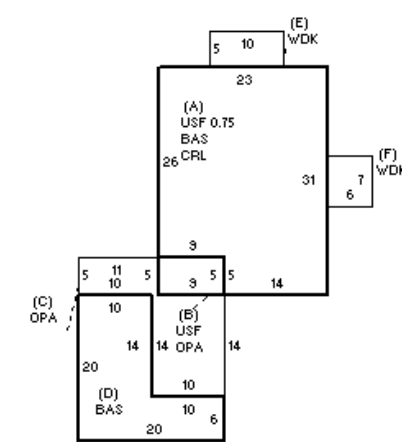

BUILDING

BUILDING	CD	ADJ	DESC	MEASURE	10/8/2009	PL
MODEL	1		RESIDENTIAL	LIST	10/8/2009	EST
STYLE	4	1.10	CAPE [100%]	REVIEW	3/8/2011	ER
QUALITY	A	1.00	AVERAGE [100%]			
FRAME	1	1.00	WOOD FRAME [100%]			

BLDG COMMENTS

G

YEAR BLT	1920	SIZE ADJ	1.000	ELEMENT	CD	DESCRIPTION	ADJ	S	BAT	T	DESCRIPTION	UNITS	YB	ADJ PRICE	RCN	TOTAL RCN	373,159		
NET AREA	1,474	DETAIL ADJ	1.100	FOUNDATION	4	CONT BSMT WALL	1.00	A	CRL	N	BSMT CRAWL	668		12.02	8,031	CONDITION ELEM	CD		
\$NLA(RCN)	\$253	OVERALL	1.000	EXT COVER	2	CLAPBOARD	1.00	+	USF	L	UPPER STORY FIN	546	1920	214.88	117,323	EXTERIOR			
				ROOF SHAPE	1	GABLE	1.00	+	OPA	N	OPEN PORCH	240		51.50	12,360	INTERIOR			
				ROOF COVER	1	ASPH SHINGLES	1.00	+	BAS	L	BASE AREA	928	1920	236.29	219,273	KITCHEN			
				FLOOR COVER	2	SOFTWOOD	1.00	+	WDK	N	WOOD DECK	92		38.40	3,533	BATHS			
				INT FINISH	1	PLASTER	1.00	F21	O	FPL 2S 1OP	1		8,239.00	8,239	HEAT				
				HEATING/COOLING	99	N/A	1.00								ELECT				
				FUEL SOURCE	99	N/A	1.00												
CAPACITY			UNITS	ADJ														EFF.YR/AGE	1972 / 50
STORIES		1.75	1.00														COND	31 31 %	
ROOMS		7	1.00														FUNC	4 PARTIAL HEAT	
BEDROOMS		3	1.00														ECON	0	
BATHROOMS		1	1.00														DEPR	35 % GD 65	
# 1/2 BATHS		1	1.00														RCNLD	\$242,600	
TOT FIXTURES		5	\$4,400																
# UNITS		1	1.00																