

Key: 775

Town of SCITUATE - Fiscal Year 2024

10/18/2023 5:31 pm SEQ #: 713

LEGAL

LAND

CURRENT OWNER				PARCEL ID				LOCATION			
LOWRY DANIEL S & JOAN M 29 WILLIAMSBURG LN SCITUATE, MA 02066				37-2-4-Q				29 WILLIAMSBURG LN			
TRANSFER HISTORY				DOS	T	SALE PRICE	BK-PG (Cert)				
LOWRY DANIEL S & JOAN M				07/19/2013	F	1	43371-285				
LOWRY DANIEL V & JOAN M				05/15/1996	QS	232,000	14362-38				
SACK STACY E				03/12/1992	QS	181,500	10819-98				

CLASS	CLASS%	DESCRIPTION			BN ID	BN	CARD	
1010	100	SINGLE FAMILY				1	1 of 1	
PMT NO	PMT DT	TY	DESC	AMOUNT	INSP	BY	1st	%
10-096	03/30/2010	3	ALTERATIONS	8,800	08/06/2010	SJ	100	100
09-149	04/24/2009	3	ALTERATIONS	6,250	07/28/2009	SJ	100	100
08-332	07/23/2008	3	ALTERATIONS	7,500	07/28/2009	SJ	100	100
04-491	08/02/2004	2	ADDITIONS		06/08/2005	SJ	100	100

CD	T	AC/SF/UN	Ngh	Inf1	Inf2	ADJ BASE	SAF	Inf3	Lpi	VC	CREDIT AMT	ADJ VALUE
100	S	40,000	SC	1.00	100	1.00	100	1.00	R05	1.10		444,440
300	A	0.742	SC	1.00	100	1.00	100	1.00	R05	1.10		11,310

TOTAL	1.660 Acres	ZONING	FRNT	115	ASSESSED	CURRENT	PREVIOUS
Ngh	SCITUATE	NOTE			LAND	455,800	414,900
Inf1	FACTOR 100		BUILDING	385,600	343,000		
Inf2	PHY 100		DETACHED	0	0		
			OTHER	0	0		
			TOTAL		841,400	757,900	

DETACHED

TY	QUAL	COND	DIM/NOTE	YB	UNITS	ADJ PRICE	RCNLD

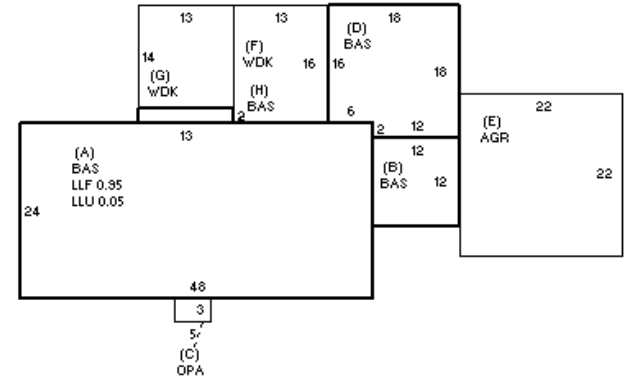

BUILDING	CD	ADJ	DESC	MEASURE	8/6/2010	SJ
MODEL	1		RESIDENTIAL	LIST	8/6/2010	EST
STYLE	2	1.00	RAISED RANCH [100%]	REVIEW	3/9/2011	KT
QUALITY	A	1.00	AVERAGE [100%]			
FRAME	1	1.00	WOOD FRAME [100%]			

BUILDING

YEAR BLT	1960	SIZE ADJ	1.000	ELEMENT	CD	DESCRIPTION	ADJ	S	BAT	T	DESCRIPTION	UNITS	YB	ADJ PRICE	RCN	TOTAL RCN	521,096
NET AREA	2,728	DETAIL ADJ	1.020	FOUNDATION	4	CONT BSMT WALL	1.00	A	LLU	N	LOWER LEVEL UNF	58		56.55	3,280		
\$NLA(RCN)	\$191	OVERALL	1.000	EXT COVER	1	WD SHINGLES	1.00	A	LLF	L	LOWER LEVEL FIN	1,094	1960	134.37	146,998		
				ROOF SHAPE	1	GABLE	1.00	+	BAS	L	BASE AREA	1,322	1960	194.80	257,532		
				ROOF COVER	1	ASPH SHINGLES	1.00	C	OPA	N	OPEN PORCH	15		51.53	773		
				FLOOR COVER	99	N/A	1.00	D	BAS	L	BASE AREA	312	2004	194.80	60,779		
				INT FINISH	99	N/A	1.00	E	AGR	N	ATT GARAGE	484		44.45	21,515		
				HEATING/COOLING	2	HOT WATER	1.02	+	WDK	N	WOOD DECK	390		38.40	14,976		
				FUEL SOURCE	99	N/A	1.00	F12	O		FPL 1S 2OP	1		10,347.00	10,347		
																CONDITION ELEM	CD
																EXTERIOR	
																INTERIOR	
																KITCHEN	
																BATHS	
																HEAT	
																ELECT	
																EFF.YR/AGE	1985 / 37
																COND	26 26 %
																FUNC	0
																ECON	0
																DEPR	26 % GD 74
																RCNLD	\$385,600