

Key: 788

Town of SCITUATE - Fiscal Year 2024

10/18/2023 5:31 pm SEQ #: 726

LEGAL

CURRENT OWNER				PARCEL ID				LOCATION				
MALOUF EDWARD P & CAROL LIEB MALOUF 433 COUNTRY WAY SCITUATE, MA 02066				32-7-5-0				433 COUNTRY WAY				
				TRANSFER HISTORY				DOS	T	SALE PRICE	BK-PG (Cert)	
				MALOUF EDWARD P & D'ONOFRIO MARK A & NANCY				01/13/2006	QS	460,000	32068-290	
				GREEN JE, PS, RW, RP, ALT				04/15/1992	QS	127,000	10903-37	
								06/24/1991	XX		10344-75	

CLASS	CLASS%	DESCRIPTION			BN ID	BN	CARD
1010	100	SINGLE FAMILY				1	1 of 1
PMT NO	PMT DT	TY	DESC	AMOUNT	INSP	BY	1st %
98-204	05/18/1998	2	ADDITIONS				100
		7	OTHERS				100

LAND

CD	T	AC/SF/UN	Ngh	Infl1	Infl2	ADJ BASE	SAF	Infl3	Lpi	VC	CREDIT AMT	ADJ VALUE
100	S	14,725	SC	1.00	1.00	396,000	2.48	1.00	R02	0.90		332,640

TOTAL	14,725 SF	ZONING	NOOTE	FRNT	63	ASSESSED	CURRENT	PREVIOUS
Ngh	SCITUATE					LAND	332,600	319,200
Infl1	FACTOR 100					BUILDING	203,400	191,000
Infl2	PHY 100					DETACHED	4,700	4,500
						OTHER	0	0
						TOTAL	540,700	514,700

DETACHED

TY	QUAL	COND	DIM/NOTE	YB	UNITS	ADJ PRICE	RCNLD
DGF	A	1.00	60 0.40 GARAGE		216	54.75	4,700

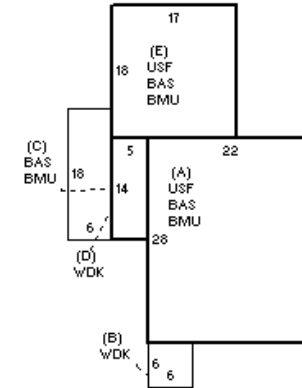

BUILDING

BUILDING	CD	ADJ	DESC	MEASURE	4/27/2009	PL
MODEL	1		RESIDENTIAL	LIST		
STYLE	7	1.20	CONVENTIONAL [100%]	REVIEW	3/9/2011	KT
QUALITY	+	1.10	AVG +/GOOD - [100%]			
FRAME	1	1.00	WOOD FRAME [100%]			

BLDG COMMENTS
SALES REVIEW/FY12 FR-COL TO CONV

G

YEAR BLT	1910	SIZE ADJ	1.000	ELEMENT	CD	DESCRIPTION	ADJ	S	BAT	T	DESCRIPTION	UNITS	YB	ADJ PRICE	RCN	TOTAL RCN	564,957	
NET AREA	1,914	DETAIL ADJ	1.224	FOUNDATION	5	BRICK/STONE	1.00	+	BMU	N	BSMT UNFINISHED	992		52.01	51,590	CONDITION ELEM	CD	
\$NLA(RCN)	\$295	OVERALL	1.000	EXT COVER	1	WD SHINGLES	1.00	+	BAS	L	BASE AREA	992	1910	273.60	271,415	EXTERIOR		
				ROOF SHAPE	3	GAMBREL	1.00	+	USF	L	UPPER STORY FIN	922	1910	248.81	229,406	INTERIOR		
				ROOF COVER	1	ASPH SHINGLES	1.00	+	WDK	N	WOOD DECK	144		42.24	6,083	KITCHEN		
				FLOOR COVER	99	N/A	1.00									BATHS		
				INT FINISH	99	N/A	1.00									HEAT		
				HEATING/COOLING	2	HOT WATER	1.02									ELECT		
				FUEL SOURCE	99	N/A	1.00											
																	EFF.YR/AGE	1952 / 70
																	COND	64 64 %
																	FUNC	0
																	ECON	0
																	DEPR	64 % GD 36
																	RCNLD	\$203,400