

Key: 7929

Town of SCITUATE - Fiscal Year 2024

10/18/2023 5:31 pm SEQ #: 7.601

LEGALLAND

CURRENT OWNER				PARCEL ID				LOCATION			
SCITUATE HARBOR YACHT CLUB 84 JERICHO RD SCITUATE, MA 02066				46-5-56-F				84 JERICHO RD			
TRANSFER HISTORY				DOS	T	SALE PRICE	BK-PG (Cert)				
SCITUATE HARBOR YACHT CLU				01/01/1941	QS		6921-N/A				

CLASS	CLASS%	DESCRIPTION			BN ID	BN	CARD	
3840	100	MARINAS				1	1 of 5	
PMT NO	PMT DT	TY	DESC	AMOUNT	INSP	BY	1st	%
21-243	03/16/2021	3	ALTERATIONS	18,500	08/04/2021	JD	100	100
20-128	02/25/2020	3	ALTERATIONS	33,400	07/17/2020	JD	100	100
14-266		7	OTHERS	2,000	07/01/2014	MR	100	100
11-618	09/29/2011	2	ADDITIONS		09/11/2012	SJ	100	100

CD	T	AC/SF/UN	Ngh	Infl1	Infl2	ADJ BASE	SAF	Infl3	Lpi	VC	CREDIT AMT	ADJ VALUE	
103	S	43,560	C09 1.00	200	2.00	100	1.00	1,808,550	1.00	100	1.00	C09 2.25	1,808,550
203	A	1,340	C09 1.00	200	2.00	100	1.00	904,500	1.00	100	1.00	C09 2.25	1,212,030

TOTAL	2.340 Acres	ZONING	FRNT	723	ASSESSED	CURRENT	PREVIOUS
Ngh	9	NOTE			LAND	3,020,600	2,893,900
Infl1	FACTOR 200				BUILDING	570,700	544,900
Infl2	PHY 100				DETACHED	502,400	475,300
					OTHER	560,800	537,200
					<b>TOTAL</b>	<b>4,654,500</b>	<b>4,451,300</b>

TY	QUAL	COND	DIM/NOTE	YB	UNITS	ADJ PRICE	RCNLD
PAV	A	1.00	50 0.50		30,000	3.40	51,000
C06	A	1.00	50 0.50		350	16.70	2,900
SW2	E	1.80	30 0.70		20	65.52	900
DDK	V	1.50	50 0.50 DECK/PIERS		8,000	28.72	114,900
S/V	A	1.00	SV 1.00 1444 S/F DOC		65,000	1.10	71,500
IPC	E	1.80	20 0.80 30 X 75		2,250	52.23	94,000
UTB	A	1.00	20 0.80 12X12		144	29.09	3,400
PBD	V	1.50	20 0.80 DRESS RM	1978	224	35.55	6,400
PBD	V	1.50	20 0.80 DRESS RM	1978	224	35.55	6,400
PBD	V	1.50	20 0.80 DRESS RM	1978	224	35.55	6,400
PBD	V	1.50	20 0.80 DRESS RM	1978	224	35.55	6,400
PBD	V	1.50	20 0.80 DRESS RM	1978	128	35.55	3,600
PBD	V	1.50	20 0.80 DRESS RM		132	35.55	3,800
PBD	V	1.50	20 0.80 DRESS RM		132	35.55	3,800
PBD	V	1.50	20 0.80 DRESS RM		132	35.55	3,800
PBD	V	1.50	20 0.80 DRESS RM		132	35.55	3,800



BLDG COMMENTS

SCITUATE HARBOR YACHT CLUB

BUILDING	CD	ADJ	DESC	MEASURE	12/22/2021	PJK
MODEL	5		CIM-5	LIST	5/3/2011	DF
STYLE	39	0.83	RESTAURANT [100%]	REVIEW	7/17/2020	JD
QUALITY	G	1.10	GOOD [100%]			
FRAME	1	1.00	WOOD FRAME [100%]			

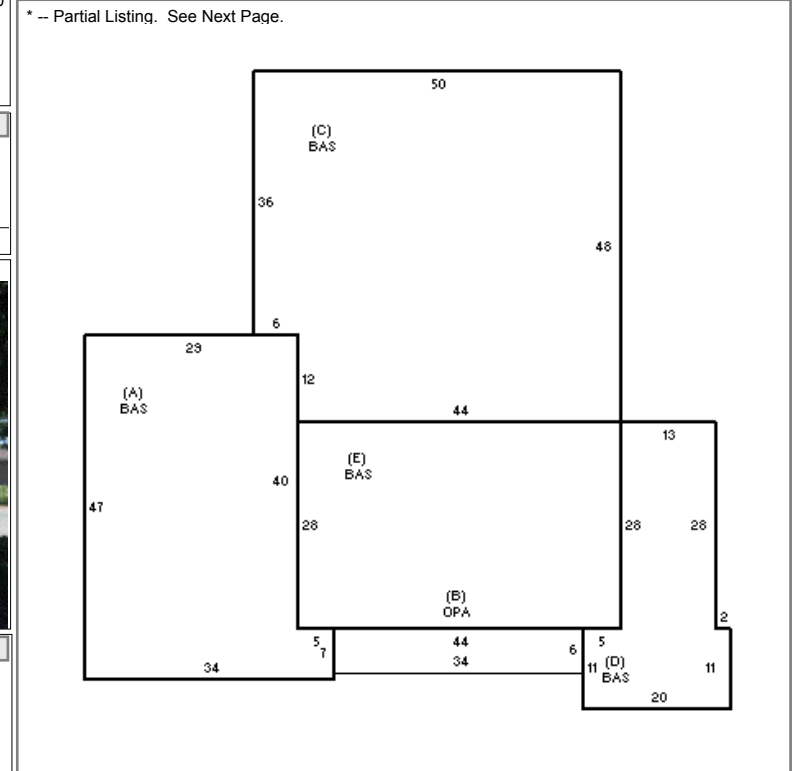

DETACHED

BUILDING

YEAR BLT	1930	SIZE ADJ	1.000	ELEMENT	CD	DESCRIPTION	ADJ	S	BAT	T	DESCRIPTION	UNITS	YB	ADJ PRICE	RCN	TOTAL RCN	771,166		
NET AREA	5,542	DETAIL ADJ	0.813	FOUNDATION	2	SLAB	1.00	+	BAS	L	BASE AREA	1,982	1930	138.02	273,547	CONDITION ELEM	CD		
\$NLA(RCN)	\$139	OVERALL	1.000	EXT. COVER	7	STUCCO	1.00	B	OPA	N	OPEN PORCH	204		30.80	6,283	EXTERIOR	G		
				ROOF SHAPE	1	GABLE	1.00	C	BAS	L	BASE AREA	2,328	1930	138.02	321,301	INTERIOR	G		
				ROOF COVER	1	ASPH/CMP SHIN	1.00	E	BAS	L	BASE AREA	1,232	1930	138.02	170,035	CDN/APP	G		
				FLOOR COVER	3	W/W CARPET	1.00												
				INT. FINISH	2	DRYWALL	1.00												
				HEATING/COOL	1	FORCED AIR	1.00												
				FUEL SOURCE	2	GAS	1.00												
																		EFF.YR/AGE	1991 / 31
																		COND	26 26 %
																		FUNC	0
																		ECON	0
																		DEPR	26 % GD 74
																		RCNLD	\$570,700

Key: 7929

Town of SCITUATE - Fiscal Year 2024

10/18/2023 5:31 pm SEQ #: 7.602

LEGAL

CURRENT OWNER				PARCEL ID				LOCATION			
SCITUATE HARBOR YACHT CLUB				46-5-56-F				84 JERICHO RD			
84 JERICHO RD				TRANSFER HISTORY		DOS	T	SALE PRICE	BK-PG (Cert)		
SCITUATE, MA 02066											

CLASS	CLASS%	DESCRIPTION			BN ID	BN	CARD	
3840	100	MARINAS					2 of 5	
PMT NO	PMT DT	TY	DESC	AMOUNT	INSP	BY	1st	%

LAND

CD	T	AC/SF/UN	Ngh	Infl1	Infl2	ADJ BASE	SAF	Infl3	Lpi	VC	CREDIT AMT	ADJ VALUE

\* -- Partial Listing. See Previous Page.

TOTAL	ZONING	FRNT	ASSESSED	CURRENT	PREVIOUS
Ngh	NOTE		LAND		
Infl1		BUILDING			
Infl2		DETACHED			
			OTHER		
			TOTAL		

DETACHED

TY	QUAL	COND	DIM/NOTE	* YB	UNITS	ADJ PRICE	RCNLD	PHOTO
PBD	V	1.50	20 0.80		132	35.55	3,800	
PBD	V	1.50	20 0.80		390	35.55	11,100	
PBD	V	1.50	20 0.80		72	35.55	2,000	
PBD	V	1.50	20 0.80		312	35.55	8,900	
PBD	V	1.50	20 0.80		396	35.55	11,300	
PBD	V	1.50	20 0.80		96	35.55	2,700	
PBD	V	1.50	20 0.80		128	35.55	3,600	
PBD	V	1.50	20 0.80		160	35.55	4,600	
PBD	V	1.50	20 0.80		224	35.55	6,400	
PBD	V	1.50	20 0.80		48	35.55	1,400	
DDK	A	1.00	50 0.50		3,060	19.43	29,700	
SHF	V	1.50	20 0.80		300	17.19	4,100	
SHF	V	1.50	20 0.80		154	19.53	2,400	
SHF	V	1.50	20 0.80	2-10X10	200	18.43	2,900	
CTA	A	1.00	50 0.50		2	24,469.30	24,500	

BUILDING

BUILDING	CD	ADJ	DESC	MEASURE
MODEL				LIST
STYLE				REVIEW
QUALITY				
FRAME				

YEAR BLT	NET AREA	\$NLA(RCN)	SIZE ADJ	DETAIL ADJ	OVERALL	ELEMENT	CD	DESCRIPTION	ADJ	S	BAT	T	DESCRIPTION	UNITS	YB	ADJ PRICE	RCN
CAPACITY			UNITS	ADJ													

TOTAL RCN	CONDITION ELEM	CD
EFF.YR/AGE		
COND		
FUNC		
ECON		
DEPR	% GD	
RCNLD		

Key: 7929

Town of SCITUATE - Fiscal Year 2024

10/18/2023 5:31 pm SEQ #: 7.603

LEGAL

LAND

DETACHED

BUILDING

CURRENT OWNER				PARCEL ID				LOCATION			
SCITUATE HARBOR YACHT CLUB				46-5-56-F				84 JERICO RD			
84 JERICO RD				TRANSFER HISTORY		DOS	T	SALE PRICE	BK-PG (Cert)		
SCITUATE, MA 02066											

CLASS	CLASS%	DESCRIPTION				BN ID	BN	CARD		
3840	100	MARINAS					2	3 of 5		
PMT NO	PMT DT	TY	DESC	AMOUNT	INSP	BY	1st			

CD	T	AC/SF/UN	Ngh	Infl1	Infl2	ADJ BASE	SAF	Infl3	Lpi	VC	CREDIT AMT	ADJ VALUE
----	---	----------	-----	-------	-------	----------	-----	-------	-----	----	------------	-----------

TOTAL	ZONING	FRNT	ASSESSED	CURRENT	PREVIOUS
Ngh	NOTE		LAND	186,800	
Infl1		BUILDING			
Infl2		DETACHED			
			OTHER		
			TOTAL		

TY	QUAL	COND	DIM/NOTE	YB	UNITS	ADJ PRICE	RCNLD	PHOTO
----	------	------	----------	----	-------	-----------	-------	-------

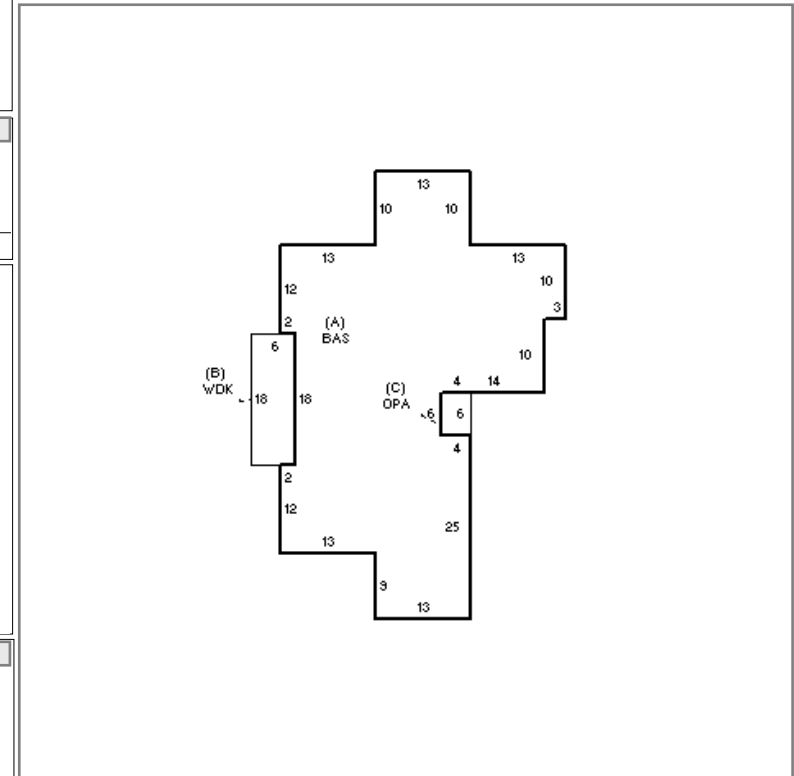

BUILDING	CD	ADJ	DESC	MEASURE	12/22/2021	PJK	BLDG COMMENTS
MODEL	5		CIM-5	LIST	5/3/2011	DF	ACTIVITIES BUILDING
STYLE	71	0.60	CLUB/LODGE/HALL [100%]	REVIEW	3/16/2011	DF	
QUALITY	G	1.10	GOOD [100%]				
FRAME	1	1.00	WOOD FRAME [100%]				

YEAR BLT	1978	SIZE ADJ	1.000	ELEMENT	CD	DESCRIPTION	ADJ	S	BAT	T	DESCRIPTION	UNITS	YB	ADJ PRICE	RCN
NET AREA	1,509	DETAIL ADJ	0.576	FOUNDATION	1	PIER	1.00	A	BAS	L	BASE AREA	1,509	1978	148.71	224,403
\$NLA(RCN)	\$151	OVERALL	1.000	EXT. COVER	10	VERT. BOARD	1.00	B	WDK	N	WOOD DECK	108		24.20	2,614
				ROOF SHAPE	1	GABLE	1.00	C	OPA	N	OPEN PORCH	24		30.79	739
				ROOF COVER	1	ASPH/CMP SHIN	1.00								
				FLOOR COVER	3	W/W CARPET	1.00								
				INT. FINISH	2	DRYWALL	1.00								
				HEATING/COOL	1	FORCED AIR	1.00								
				FUEL SOURCE	2	GAS	1.00								

TOTAL RCN	227,756	
CONDITION ELEM	CD	
EXTERIOR	G	
INTERIOR	G	
CDN/APP	G	
EFF.YR/AGE	2004 / 18	
COND	18	18 %
FUNC	0	
ECON	0	
DEPR	18	% GD 82
RCNLD	\$186,800	

Key: 7929

Town of SCITUATE - Fiscal Year 2024

10/18/2023 5:31 pm SEQ #: 7.604

LEGAL

CURRENT OWNER		PARCEL ID		LOCATION	
SCITUATE HARBOR YACHT CLUB 84 JERICO RD SCITUATE, MA 02066		46-5-56-F		84 JERICO RD	
TRANSFER HISTORY		DOS	T	SALE PRICE	BK-PG (Cert)

CLASS	CLASS%	DESCRIPTION			BN ID	BN	CARD	
3840	100	MARINAS				3	4 of 5	
PMT NO	PMT DT	TY	DESC	AMOUNT	INSP	BY	1st	%

LAND

CD	T	AC/SF/UN	Ngh	Inf1	Inf2	ADJ BASE	SAF	Inf3	Lpi	VC	CREDIT AMT	ADJ VALUE

TOTAL	ZONING	FRNT	ASSESSED	CURRENT	PREVIOUS
Ngh	NOTE		LAND	125,600	
Inf1		BUILDING			
Inf2		DETACHED			
			OTHER		
			TOTAL		

DETACHED

TY	QUAL	COND	DIM/NOTE	YB	UNITS	ADJ PRICE	RCNLD

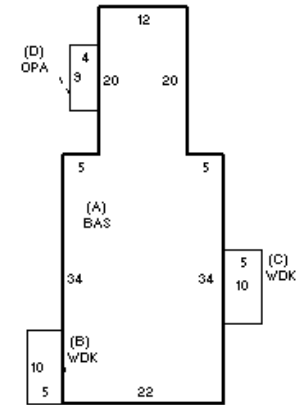

BUILDING

BUILDING	CD	ADJ	DESC	MEASURE	12/22/2021
MODEL	5		CIM-5	LIST	5/3/2011 DF
STYLE	71	0.60	CLUB/LODGE/HALL [100%]	REVIEW	3/16/2011 DF
QUALITY	A	1.00	AVERAGE [100%]		
FRAME	1	1.00	WOOD FRAME [100%]		

BLDG COMMENTS

POOL HOUSE & REST ROOMS

INDING

YEAR BLT	1980	SIZE ADJ	1.000	ELEMENT	CD	DESCRIPTION	ADJ	S	BAT	T	DESCRIPTION	UNITS	YB	ADJ PRICE	RCN	TOTAL RCN	153,190		
NET AREA	988	DETAIL ADJ	0.519	FOUNDATION	2	SLAB	1.00	A	BAS	L	BASE AREA	988	1980	151.80	149,982	CONDITION ELEM	CD		
\$NLA(RCN)	\$155	OVERALL	1.000	EXT. COVER	10	VERT. BOARD	1.00	+	WDK	N	WOOD DECK	100		22.00	2,200	EXTERIOR	G		
				ROOF SHAPE	1	GABLE	1.00	D	OPA	N	OPEN PORCH	36		28.00	1,008	INTERIOR	G		
				ROOF COVER	1	ASPH/CMP SHIN	1.00											CDN/APP	G
				FLOOR COVER	5	VINYL	1.00												
				INT. FINISH	2	DRYWALL	1.00											EFF.YR/AGE	2004 / 18
				HEATING/COOL	13	NONE	0.95											COND	18 18 %
				FUEL SOURCE	8	NONE	1.00											FUNC	0
														ECON	0				
														DEPR	18 % GD 82				
														RCNLD	\$125,600				

Key: 7929

Town of SCITUATE - Fiscal Year 2024

10/18/2023 5:31 pm SEQ #: 7.605

LEG  
AL

CURRENT OWNER				PARCEL ID				LOCATION			
SCITUATE HARBOR YACHT CLUB 84 JERICHO RD SCITUATE, MA 02066				46-5-56-F				84 JERICHO RD			
TRANSFER HISTORY				DOS	T	SALE PRICE	BK-PG (Cert)				

CLASS	CLASS%	DESCRIPTION				BN ID	BN	CARD	
3840	100	MARINAS					4	5 of 5	
PMT NO	PMT DT	TY	DESC	AMOUNT	INSP	BY	1st	%	

LAN  
D

CD	T	AC/SF/UN	Ngh	Infl1	Infl2	ADJ BASE	SAF	Infl3	Lpi	VC	CREDIT AMT	ADJ VALUE

TOTAL	ZONING	FRNT	ASSESSED	CURRENT	PREVIOUS
Ngh	NOTE		LAND	248,400	
Infl1		BUILDING			
Infl2		DETACHED			
			OTHER		
			TOTAL		

DET  
ACH  
ED

TY	QUAL	COND	DIM/NOTE	YB	UNITS	ADJ PRICE	RCNLD	PHOTO

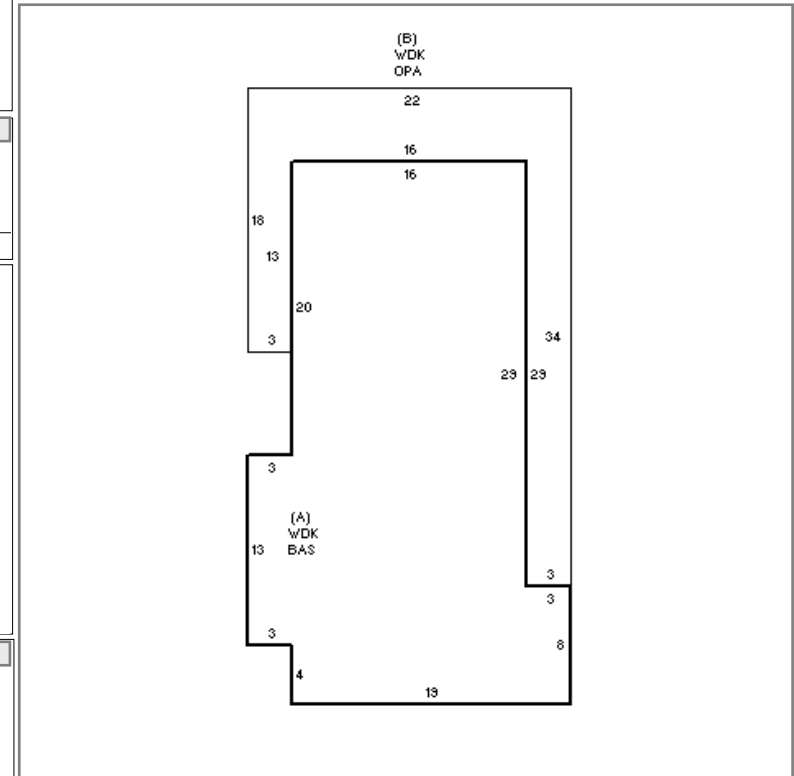

B  
U  
I  
L  
D  
I  
N  
G

BUILDING	CD	ADJ	DESC	MEASURE
MODEL	5		CIM-5	LIST
STYLE	39	0.83	RESTAURANT [100%]	REVIEW
QUALITY	G	1.10	GOOD [100%]	
FRAME	1	1.00	WOOD FRAME [100%]	

YEAR BLT	2012	SIZE ADJ	1.000	ELEMENT	CD	DESCRIPTION	ADJ	S	BAT	T	DESCRIPTION	UNITS	YB	ADJ PRICE	RCN
NET AREA	655	DETAIL ADJ	0.806	FOUNDATION	2	SLAB	1.00	A	BAS	L	BASE AREA	655	2012	335.27	219,602
\$NLA(RCN)	\$379	OVERALL	1.000	EXT. COVER	1	WOOD SHINGLE	1.00	+	WDK	N	WOOD DECK	891		24.20	21,562
				ROOF SHAPE	4	FLAT/SHED	0.98	B	OPA	N	OPEN PORCH	236		30.80	7,269
				ROOF COVER	9	OTHER	1.00								
				FLOOR COVER	3	W/W CARPET	1.00								
				INT. FINISH	2	DRYWALL	1.00								
				HEATING/COOL	9	WARM/COOL AIR	1.00								
				FUEL SOURCE	2	GAS	1.00								

TOTAL RCN	248,433
CONDITION ELEM	CD
EXTERIOR	G
INTERIOR	G
CDN/APP	G
EFF.YR/AGE	2022 / 0
COND	0 0 %
FUNC	0
ECON	0
DEPR	0 % GD 100
RCNLD	\$248,400