

Key: 8420

Town of SCITUATE - Fiscal Year 2024

10/18/2023 5:31 pm SEQ #: 8.027

LEGAL

CURRENT OWNER				PARCEL ID				LOCATION			
MOORE JAMES F & LAURA 34 TACK FACTORY POND DR SCITUATE, MA 02066				42-4-13-0				34 TACK FACTORY POND DR			
TRANSFER HISTORY				DOS	T	SALE PRICE	BK-PG (Cert)				
MOORE JAMES F & LAURA				06/27/2003	QS	645,000	25598-64				
STRONG MARY				02/19/2002	P	1	21561-161				
STRONG JOHN D III & MARY				01/17/1992	QS		10704-323				

CLASS	CLASS%	DESCRIPTION			BN ID	BN	CARD	
1010	100	SINGLE FAMILY				1	1 of 1	
PMT NO	PMT DT	TY	DESC	AMOUNT	INSP	BY	1st	%
13-674	10/01/2013	3	ALTERATIONS	11,700	09/29/2014	RJM	100	100
99-201	05/11/1999	3	ALTERATIONS				100	100
99-38	02/09/1999	3	ALTERATIONS				100	100
92-23	01/10/1992	1	NEW CONST				100	100

LAND

CD	T	AC/SF/UN	Ngh	Infl1	Infl2	ADJ BASE	SAF	Infl3	Lpi	VC	CREDIT AMT	ADJ VALUE
100	S	40,000	WS 1.00	100	1.00	484,000	1.00	100	1.00	TFP	1.10	444,440
300	A	0.028	WS 1.00	100	1.00	21,780	1.00	100	1.00	TFP	1.10	610

TOTAL	41,237 SF	ZONING	FRNT	191	ASSESSED	CURRENT	PREVIOUS
Ngh	W. SCITUATE	NOTE			LAND	445,100	367,800
Infl1	FACTOR 100		BUILDING	483,400	452,800		
Infl2	PHY 100		DETACHED	0	0		
			OTHER	0	0		
			TOTAL		928,500	820,600	

DETACHED

TY	QUAL	COND	DIM/NOTE	YB	UNITS	ADJ PRICE	RCNLD

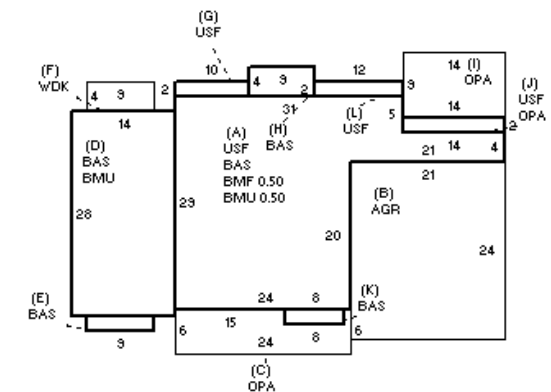

BLDG COMMENTS

BUILDING

BUILDING	CD	ADJ	DESC	MEASURE	5/4/2015	SJ
MODEL	1		RESIDENTIAL	LIST	5/4/2015	EST
STYLE	5	1.00	COLONIAL [100%]	REVIEW	10/3/2014	RJM
QUALITY	+	1.10	AVG +/GOOD - [100%]			
FRAME	1	1.00	WOOD FRAME [100%]			

INDING

YEAR BLT	1992	SIZE ADJ	1.000	ELEMENT	CD	DESCRIPTION	ADJ	S	BAT	T	DESCRIPTION	UNITS	YB	ADJ PRICE	RCN	TOTAL RCN	589,515				
NET AREA	2,164	DETAIL ADJ	1.020	FOUNDATION	4	CONT BSMT WALL	1.00	+	BMU	N	BSMT UNFINISHED	800		49.32	39,456	CONDITION ELEM	CD				
\$NLA(RCN)	\$272	OVERALL	1.000	EXT COVER	2	CLAPBOARD	1.00	A	BMF	N	BSMT FINISH-SEP	408		69.24	28,248	EXTERIOR					
				ROOF SHAPE	1	GABLE	1.00	B	AGR	N	ATT GARAGE	504		48.41	24,400	INTERIOR					
				ROOF COVER	1	ASPH SHINGLES	1.00	+	OPA	N	OPEN PORCH	282		56.65	15,975	KITCHEN					
				FLOOR COVER	13	COMB	1.00	+	BAS	L	BASE AREA	1,277	1992	223.04	284,818	BATHS					
				INT FINISH	2	DRYWALL	1.00	F	WDK	N	WOOD DECK	36		42.23	1,520	HEAT					
				HEATING/COOLING	2	HOT WATER	1.02	+	USF	L	UPPER STORY FIN	887	1992	202.83	179,908	ELECT					
				FUEL SOURCE	99	N/A	1.00		F11	O	FPL 1S 1OP	1		8,009.10	8,009						
																		EFF.YR/AGE	2004 / 18		
																		COND	17 17 %		
																		FUNC	0		
																		ECON	0		
																		DEPR	18	% GD	82
																		RCNLD	\$483,400		