

Key: 8426

Town of SCITUATE - Fiscal Year 2024

10/18/2023 5:31 pm SEQ #: 8.033

LEGAL

CURRENT OWNER				PARCEL ID				LOCATION			
KIDDIE ROSS J & TRACY A 7 ALEWIFE LANE SCITUATE, MA 02066				42-4-19-0				7 ALEWIFE LN			
TRANSFER HISTORY				DOS	T	SALE PRICE	BK-PG (Cert)				
KIDDIE ROSS J & TRACY A				12/03/1991	D	71,000	10619-75				
FIRST AMERICAN FINANCIAL				09/05/1990	XX		9931-121				

CLASS	CLASS%	DESCRIPTION			BN ID	BN	CARD	
1010	100	SINGLE FAMILY				1	1 of 1	
PMT NO	PMT DT	TY	DESC	AMOUNT	INSP	BY	1st	%
10-593	12/10/2010	4	DEMO		08/02/2011	SJ	100	100
10-593	12/10/2010	1	NEW CONST		08/02/2011	SJ	100	100
91-673	11/19/1991	1	NEW CONST				100	100
		6	CYCL GROWTH				100	100

LAND

CD	T	AC/SF/UN	Ngh	Inf1	Inf2	ADJ BASE	SAF	Inf3	Lpi	VC	CREDIT AMT	ADJ VALUE	
100	S	40,000	WS 1.00	100	1.00	100	1.00	484,000	1.00	100	1.00	TFP 1.10	444,440

TOTAL	39,988 SF	ZONING	FRNT	391	ASSESSED	CURRENT	PREVIOUS
Ngh	W. SCITUATE	NOTE	LAND	444,400	367,300		
Inf1	FACTOR 100		BUILDING	757,600	709,000		
Inf2	PHY 100		DETACHED	0	0		
			OTHER	0	0		
			TOTAL	1,202,000	1,076,300		

DETACHED

TY	QUAL	COND	DIM/NOTE	YB	UNITS	ADJ PRICE	RCNLD

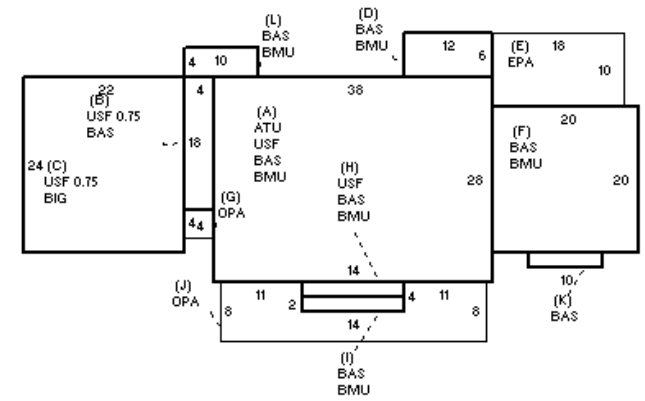

BUILDING

BUILDING	CD	ADJ	DESC	MEASURE	8/2/2011	SJ
MODEL	1		RESIDENTIAL	LIST	8/2/2011	SJ
STYLE	5	1.00	COLONIAL [100%]	REVIEW		
QUALITY	+	1.10	AVG +/GOOD - [100%]			
FRAME	1	1.00	WOOD FRAME [100%]			

BLDG COMMENTS  
FY12 QUALITY CHANGE FROM VG TO AVG+ PER FIELD REVIEW.

LOADING

YEAR BLT	2011	SIZE ADJ	1.000	ELEMENT	CD	DESCRIPTION	ADJ	S	BAT	T	DESCRIPTION	UNITS	YB	ADJ PRICE	RCN	TOTAL RCN	860,860													
NET AREA	3,266	DETAIL ADJ	1.030	FOUNDATION	4	CONT BSMT WALL	1.00	+	BMU	N	BSMT UNFINISHED	1,632		46.12	75,275															
\$NLA(RCN)	\$264	OVERALL	1.000	EXT COVER	2	CLAPBOARD	1.00	+	USF	L	UPPER STORY FIN	1,542	2011	192.87	297,406															
				ROOF SHAPE	1	GABLE	1.00	A	ATU	N	ATTIC UNF	1,064		40.70	43,305															
				ROOF COVER	1	ASPH SHINGLES	1.00	+	BAS	L	BASE AREA	1,724	2011	212.09	365,638															
				FLOOR COVER	13	COMB	1.00	C	BIG	N	BUILT-IN GARAGE	528		49.32	26,039															
				INT FINISH	2	DRYWALL	1.00	E	EPA	N	ENCLOSED PORCH	180		99.22	17,860															
				HEATING/COOLING	9	WARM/COOL AIR	1.03	+	OPA	N	OPEN PORCH	248		56.65	14,049															
				FUEL SOURCE	1	OIL	1.00	GFP	O	O	GAS FIREPLACE	2		6,112.15	12,224															
<table border="1"> <tr> <th>CONDITION ELEM</th> <th>CD</th> </tr> <tr> <td>EXTERIOR</td> <td></td> </tr> <tr> <td>INTERIOR</td> <td></td> </tr> <tr> <td>KITCHEN</td> <td></td> </tr> <tr> <td>BATHS</td> <td></td> </tr> <tr> <td>HEAT</td> <td></td> </tr> <tr> <td>ELECT</td> <td></td> </tr> </table>																CONDITION ELEM	CD	EXTERIOR		INTERIOR		KITCHEN		BATHS		HEAT		ELECT		
CONDITION ELEM	CD																													
EXTERIOR																														
INTERIOR																														
KITCHEN																														
BATHS																														
HEAT																														
ELECT																														
<table border="1"> <tr> <th>EFF.YR/AGE</th> <td colspan="2">2010 / 12</td> </tr> <tr> <td>COND</td> <td>12</td> <td>12 %</td> </tr> <tr> <td>FUNC</td> <td>0</td> <td></td> </tr> <tr> <td>ECON</td> <td>0</td> <td></td> </tr> <tr> <td>DEPR</td> <td>12</td> <td>% GD 88</td> </tr> </table>																EFF.YR/AGE	2010 / 12		COND	12	12 %	FUNC	0		ECON	0		DEPR	12	% GD 88
EFF.YR/AGE	2010 / 12																													
COND	12	12 %																												
FUNC	0																													
ECON	0																													
DEPR	12	% GD 88																												
<table border="1"> <tr> <th>RCNLD</th> <td>\$757,600</td> </tr> </table>																RCNLD	\$757,600													
RCNLD	\$757,600																													