

Key: 8446

Town of SCITUATE - Fiscal Year 2024

10/18/2023 5:31 pm SEQ #: 8.053

LEGAL

CURRENT OWNER				PARCEL ID				LOCATION			
GRASSEY TIMOTHY & MARIE 10 NEAL GATE ST SCITUATE, MA 02066				58-2-2-B				10 NEAL GATE ST			
TRANSFER HISTORY				DOS	T	SALE PRICE	BK-PG (Cert)				
GRASSEY TIMOTHY & MARIE				05/15/2020	F	1	52757-207				
GRASSEY TIMOTHY, MARIE & CROLL JOHN TR & DAWN TR				08/01/2019	QS	717,500	51451-104				
				01/12/2015	F	1	45136-69				

CLASS	CLASS%	DESCRIPTION			BN ID	BN	CARD	
1010	100	SINGLE FAMILY				1	1 of 1	
PMT NO	PMT DT	TY	DESC	AMOUNT	INSP	BY	1st	%
97-452	07/31/1997	3	ALTERATIONS				100	100
93-747	12/23/1993	1	NEW CONST				100	100

LAND

CD	T	AC/SF/UN	Ngh	Inf1	Inf2	ADJ BASE	SAF	Inf3	Lpi	VC	CREDIT AMT	ADJ VALUE
100	S	40,000	GB 1.00	100	1.00	100	1.00	100	R01	0.85		343,430

DETACHED

TOTAL	39,988 SF	ZONING	FRNT 492	ASSESSED	CURRENT PREVIOUS
Ngh	GREENBUSH	NOTE		LAND	343,400 293,900
Inf1	FACTOR 100		BUILDING	583,700 541,500	
Inf2	PHY 100		DETACHED	0 0	
			OTHER	0 0	
				TOTAL	927,100 835,400

TY	QUAL	COND	DIM/NOTE	YB	UNITS	ADJ PRICE	RCNLD

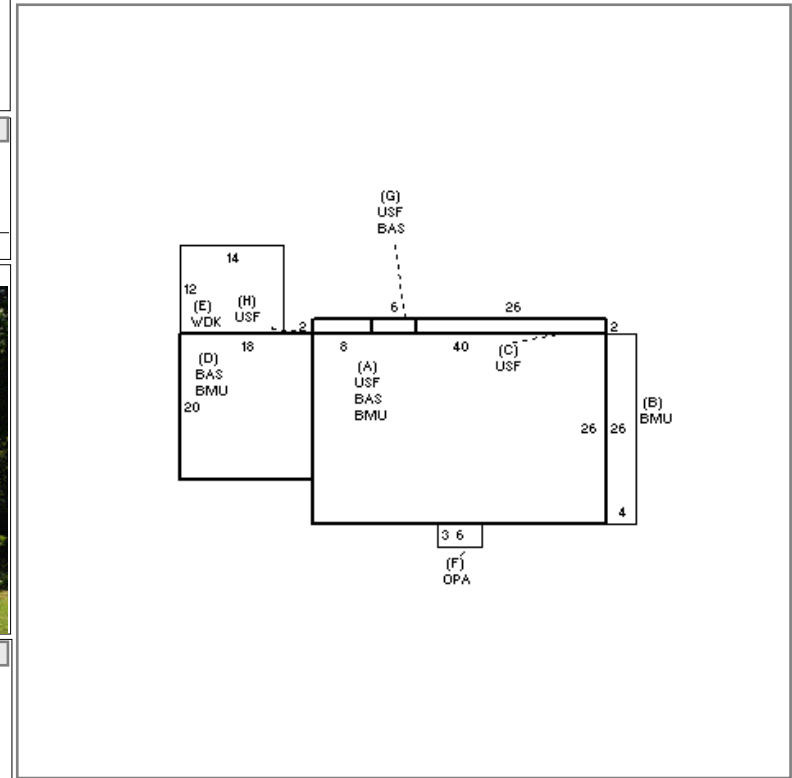

BUILDING

BUILDING	CD	ADJ	DESC	MEASURE	12/20/2010	PL
MODEL	1		RESIDENTIAL	LIST	12/20/2010	EST
STYLE	5	1.00	COLONIAL [100%]	REVIEW	9/2/2020	JD
QUALITY	+	1.10	AVG +/GOOD - [100%]			
FRAME	1	1.00	WOOD FRAME [100%]			

BLDG COMMENTS	mls
---------------	-----

INDING

YEAR BLT	1994	SIZE ADJ	1.000	ELEMENT	CD	DESCRIPTION	ADJ	S	BAT	T	DESCRIPTION	UNITS	YB	ADJ PRICE	RCN	TOTAL RCN	627,639			
NET AREA	2,532	DETAIL ADJ	1.020	FOUNDATION	4	CONT BSMT WALL	1.00	+	BMU	N	BSMT UNFINISHED	1,504		46.91	70,556	CONDITION ELEM	CD			
\$NLA(RCN)	\$248	OVERALL	1.000	EXT COVER	2	CLAPBOARD	1.00	+	USF	L	UPPER STORY FIN	1,120	1994	197.67	221,385	EXTERIOR	G			
				ROOF SHAPE	1	GABLE	1.00	E	WDK	N	WOOD DECK	168		42.24	7,096	INTERIOR	G			
				ROOF COVER	1	ASPH SHINGLES	1.00	F	OPA	N	OPEN PORCH	18		56.65	1,020	KITCHEN	G			
				FLOOR COVER	13	COMB	1.00	+	BAS	L	BASE AREA	1,412	1994	217.36	306,912	BATHS	G			
				INT FINISH	2	DRYWALL	1.00		BMG	O	BSMT GARAGE	2		2,740.10	5,480	HEAT	U			
				HEATING/COOLING	2	HOT WATER	1.02		F11	O	FPL 1S 10P	1		8,009.10	8,009	ELECT	U			
				FUEL SOURCE	1	OIL	1.00													
																		EFF.YR/AGE	2015 / 7	
																		COND	7 7 %	
																		FUNC	0	
																		ECON	0	
																		DEPR	7 % GD 93	
																		RCNLD	\$583,700	