

Key: 926

Town of SCITUATE - Fiscal Year 2024

10/18/2023 5:31 pm SEQ #: 860

LEGAL

| CURRENT OWNER                         |  | PARCEL ID                             |  | LOCATION        |                           |
|---------------------------------------|--|---------------------------------------|--|-----------------|---------------------------|
| HOLMES RICHARD B JR & KIMBERLY I      |  | 26-1-30-0                             |  | 520 COUNTRY WAY |                           |
| 520 COUNTRY WAY<br>SCITUATE, MA 02066 |  | TRANSFER HISTORY                      |  | DOS             | T SALE PRICE BK-PG (Cert) |
|                                       |  | HOLMES RICHARD B JR & YUSKO STEPHEN G |  | 02/04/1999      | QS 272,500 17121-191      |
|                                       |  | DAMON MARILYN P                       |  | 12/03/1997      | QS 165,000 15698-205      |
|                                       |  |                                       |  | 10/15/1992      | QS 190,000 11337-340      |

| CLASS  | CLASS% | DESCRIPTION   |      |        | BN ID | BN | CARD   |
|--------|--------|---------------|------|--------|-------|----|--------|
| 1010   | 100    | SINGLE FAMILY |      |        |       | 1  | 1 of 1 |
| PMT NO | PMT DT | TY            | DESC | AMOUNT | INSP  | BY | 1st %  |
|        |        |               |      |        |       |    |        |

LAND

| CD  | T | AC/SF/UN | Ngh | Inf1 | Inf2 | ADJ BASE | SAF | Inf3 | Lpi | VC   | CREDIT AMT | ADJ VALUE |
|-----|---|----------|-----|------|------|----------|-----|------|-----|------|------------|-----------|
| 100 | S | 26,500   | SC  | 1.00 | 100  | 1.00     | 100 | 1.00 | R02 | 0.90 |            | 348,110   |

| TOTAL | 26,500 SF  | ZONING | FRNT     | 181     | ASSESSED | CURRENT | PREVIOUS |
|-------|------------|--------|----------|---------|----------|---------|----------|
| Ngh   | SCITUATE   | NOTE   |          |         | LAND     | 348,100 | 334,100  |
| Inf1  | FACTOR 100 |        | BUILDING | 180,500 | 169,500  |         |          |
| Inf2  | PHY 100    |        | DETACHED | 11,100  | 10,600   |         |          |
|       |            |        | OTHER    | 0       | 0        |         |          |
|       |            |        |          |         | TOTAL    | 539,700 | 514,200  |

DETACHED

| TY  | QUAL | COND | DIM/NOTE     | YB | UNITS | ADJ PRICE | RCNLD  |
|-----|------|------|--------------|----|-------|-----------|--------|
| LBN | +    | 1.10 | 30 0.70 2SFR |    | 440   | 36.17     | 11,100 |

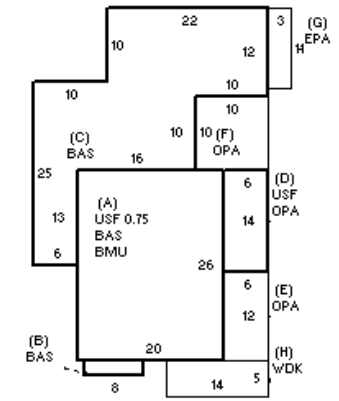

BUILDING

| BUILDING | CD | ADJ  | DESC                | MEASURE | 9/22/2010 | DR  |
|----------|----|------|---------------------|---------|-----------|-----|
| MODEL    | 1  |      | RESIDENTIAL         | LIST    | 9/22/2010 | EST |
| STYLE    | 7  | 1.20 | CONVENTIONAL [100%] | REVIEW  | 3/10/2011 | KT  |
| QUALITY  | +  | 1.10 | AVG +/GOOD - [100%] |         |           |     |
| FRAME    | 1  | 1.00 | WOOD FRAME [100%]   |         |           |     |

BLDG COMMENTS

INDING

| YEAR BLT   | 1870  | SIZE ADJ   | 1.000 | ELEMENT         | CD | DESCRIPTION   | ADJ  | S | BAT | T | DESCRIPTION     | UNITS | YB   | ADJ PRICE | RCN     | TOTAL RCN | 501,365        |            |
|------------|-------|------------|-------|-----------------|----|---------------|------|---|-----|---|-----------------|-------|------|-----------|---------|-----------|----------------|------------|
| NET AREA   | 1,592 | DETAIL ADJ | 1.224 | FOUNDATION      | 5  | BRICK/STONE   | 1.00 | A | BMU | N | BSMT UNFINISHED | 520   |      | 65.53     | 34,075  |           |                |            |
| \$NLA(RCN) | \$315 | OVERALL    | 1.000 | EXT COVER       | 2  | CLAPBOARD     | 1.00 | + | USF | L | UPPER STORY FIN | 474   | 1870 | 258.36    | 122,464 |           |                |            |
|            |       |            |       | ROOF SHAPE      | 1  | GABLE         | 1.00 | + | BAS | L | BASE AREA       | 1,118 | 1870 | 284.11    | 317,629 |           |                |            |
|            |       |            |       | ROOF COVER      | 1  | ASPH SHINGLES | 1.00 | + | OPA | N | OPEN PORCH      | 256   |      | 56.65     | 14,502  |           |                |            |
|            |       |            |       | FLOOR COVER     | 99 | N/A           | 1.00 | G | EPA | N | ENCLOSED PORCH  | 33    |      | 99.23     | 3,275   |           |                |            |
|            |       |            |       | INT FINISH      | 99 | N/A           | 1.00 | H | WDK | N | WOOD DECK       | 70    |      | 42.24     | 2,957   |           |                |            |
|            |       |            |       | HEATING/COOLING | 2  | HOT WATER     | 1.02 |   |     |   |                 |       |      |           |         |           |                |            |
|            |       |            |       | FUEL SOURCE     | 99 | N/A           | 1.00 |   |     |   |                 |       |      |           |         |           |                |            |
|            |       |            |       |                 |    |               |      |   |     |   |                 |       |      |           |         |           | CONDITION ELEM | CD         |
|            |       |            |       |                 |    |               |      |   |     |   |                 |       |      |           |         |           | EXTERIOR       |            |
|            |       |            |       |                 |    |               |      |   |     |   |                 |       |      |           |         |           | INTERIOR       |            |
|            |       |            |       |                 |    |               |      |   |     |   |                 |       |      |           |         |           | KITCHEN        |            |
|            |       |            |       |                 |    |               |      |   |     |   |                 |       |      |           |         |           | BATHS          |            |
|            |       |            |       |                 |    |               |      |   |     |   |                 |       |      |           |         |           | HEAT           |            |
|            |       |            |       |                 |    |               |      |   |     |   |                 |       |      |           |         |           | ELECT          |            |
|            |       |            |       |                 |    |               |      |   |     |   |                 |       |      |           |         |           | EFF.YR/AGE     | 1952 / 70  |
|            |       |            |       |                 |    |               |      |   |     |   |                 |       |      |           |         |           | COND           | 64 64 %    |
|            |       |            |       |                 |    |               |      |   |     |   |                 |       |      |           |         |           | FUNC           | 0          |
|            |       |            |       |                 |    |               |      |   |     |   |                 |       |      |           |         |           | ECON           | 0          |
|            |       |            |       |                 |    |               |      |   |     |   |                 |       |      |           |         |           | DEPR           | 64 % GD 36 |
|            |       |            |       |                 |    |               |      |   |     |   |                 |       |      |           |         |           | RCNLD          | \$180,500  |