

Key: 1058

Town of TRURO - Fiscal Year 2024

9/27/2023 7:11 pm SEQ #: 1.014

LEGAL

CURRENT OWNER				PARCEL ID				LOCATION			
DRAGON CHRISTINA & CHRISTOPHER PO BOX 334 NO TRURO, MA 02652				36-172-0				40 HIGHLAND RD			
TRANSFER HISTORY				DOS	T	SALE PRICE	BK-PG (Cert)				
DRAGON CHRISTINA & CHRIST GARRAN REALTY TRUST				03/31/2020	N	390,000	32799-288				
				01/19/1990	99		7028-206				

CLASS	CLASS%	DESCRIPTION			BN ID	BN	CARD	
1010	100	SINGLE FAMILY				1	1 of 1	
PMT NO	PMT DT	TY	DESC	AMOUNT	INSP	BY	1st	%
21-400	11/10/2021	80	SOLAR TAXABL	7,200				0
21-086	03/16/2021	2	ADDITION	225,000	12/20/2022	LG	100	100
20-258	09/15/2020	3	REPAIR/REMOD	9,000	01/04/2021	LG	100	100
01-205	11/19/2001	10	ALL OTHERS	13,784	04/08/2002	TG	100	100

LAND

CD	T	AC/SF/UN	Nbhd	Inf1	Inf2	ADJ BASE	SAF	Inf3	Lpi	VC	CREDIT AMT	ADJ VALUE
100	A	0.775	16	1.00	1	1.00	1	1.00	SR2	1.60		446,520
300	A	2.285	16	1.00	1	1.00	1	1.00	SR2	1.60		100,540
400	F	150	16	1.00	1	1.00	1	1.00	SR2	1.60		62,400

DETAILED

TOTAL	3.060 Acres	ZONING	NSD	FRNT	0	ASSESSED	609,500	CURRENT	1,297,200	PREVIOUS	475,600
Nbhd	NAT'L SEASHORE	NOTE SHF@223 SF=2 SHEDS ATT TO EACH OTHER.	LAND	686,100	BUILDING	1,600	OTHER	0	TOTAL	784,700	
Inf1	NO ADJ		DETACHED	1,600							
Inf2	NO ADJ		OTHER	0							

TY	QUAL	COND	DIM/NOTE	YB	UNITS	ADJ PRICE	RCNLD
SHF	A	1.00	A 0.75 4*8		32	17.17	400
SHF	L	0.83	P 0.45 IRREG		223	12.32	1,200

PHOTO 12/20/2022



**BLDG COMMENTS**  
 Primary heat: Heat pump, kept oil hot water system.  
 Sec B & K 2' high dirt CRL. Finished space abv Garage exterior access only.

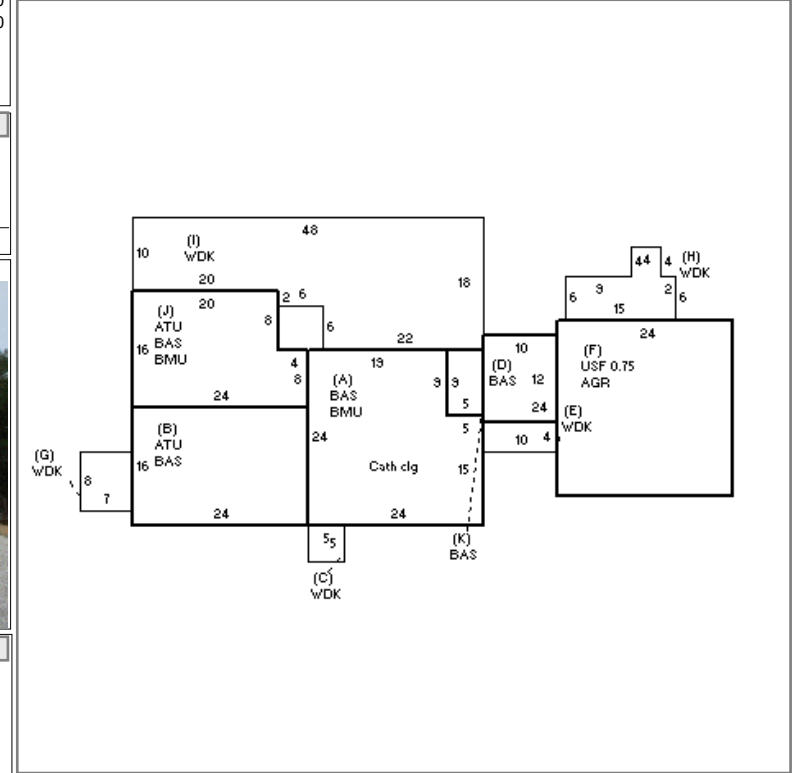

BUILDING

BUILDING	CD	ADJ	DESC	MEASURE	12/22/2021	LG
MODEL	1		RESIDENTIAL	LIST	12/20/2022	LG
STYLE	1	1.00	RANCH [100%]	REVIEW	12/15/2010	MR
QUALITY	A	1.00	AVERAGE [100%]			
FRAME	1	1.00	WOOD FRAME [100%]			

YEAR BLT	1947	SIZE ADJ	1.010	ELEMENT	CD	DESCRIPTION	ADJ	S	BAT	T	DESCRIPTION	UNITS	YB	ADJ PRICE	RCN	TOTAL RCN	797,840
NET AREA	1,864	DETAIL ADJ	1.000	FOUNDATION	4	BSMT WALL	1.00	+	BMU	N	BSMT UNFINISHED	883		75.73	66,873	CONDITION ELEM	CD
\$NLA(RCN)	\$428	OVERALL	1.040	EXT. COVER	4	VINYL	1.00	+	BAS	L	BAS AREA	1,312	1947	312.81	410,406		
CAPACITY			UNITS	ADJ	ROOF SHAPE	1	GABLE	1.00	+	ATU	N	UNFIN ATTIC	736	84.10	61,899		
STORIES(FAR)	1	1.00	ROOF COVER	1	ASPHALT SHINGLE	1.00	+	WDK	N	ATT WOOD DECK	895		47.35	42,375			
ROOMS	0	1.00	FLOOR COVER	1	HARDWOOD	1.00	D	BAS	L	BAS AREA	120	2021	312.81	37,537			
BEDROOMS	3	1.00	INT. FINISH	2	DRYWALL	1.00	F	AGR	N	ATTACHED GARAGE	576		94.93	54,681			
BATHROOMS	3	1.00	HEATING/COOLING	8	HEAT PUMP	1.04	F	USF	L	UP-STRY FIN	432	2021	251.14	108,491			
FIXTURES	6	\$4,200	FUEL SOURCE	3	ELECTRIC	1.00	F11	O	FPL 1S 1OP	1			11,379.00	11,379			
UNITS	1	1.00															
																EFF.YR/AGE	2008 / 14
																COND	14 14 %
																FUNC	0
																ECON	0
																DEPR	14 % GD 86
																RCNLD	\$686,100