

Key: 1064

Town of TRURO - Fiscal Year 2024

9/27/2023 7:11 pm SEQ #: 1.022

LEG
AL
LAND

CURRENT OWNER		PARCEL ID		LOCATION									
MAXWELL CHRISTINE A 49 NUTHATCH KNOB GLASTONBURY, CT 06033		36-178-0		24 HIGHLAND RD									
TRANSFER HISTORY		DOS	T	SALE PRICE	BK-PG (Cert)								
MAXWELL CHRISTINE A		08/18/2017	QS	415,000	30709-334								
SPARKS OLIN GENE		02/15/2007	99		11712-300+								
PACKETT MARY E &		09/21/1998	A		11712-300								
CD	T	AC/SF/UN	Nbhd	Inf1	Inf2	ADJ BASE	SAF	Inf3	Lpi	VC	CREDIT AMT	ADJ VALUE	
100	A	0.320 16	1.00	1	1.00	1	1.00	576,160	1.85	1	1.00	SR2 1.60	340,500

CLASS	CLASS%	DESCRIPTION		BN ID	BN	CARD	
1010	100	SINGLE FAMILY			1	1 of 1	
PMT NO	PMT DT	TY	DESC	AMOUNT	INSP	BY	1st %
19-215	07/23/2019	80	SOLAR TAXABL	10,000	09/18/2019	LG	100 100
19-021X	01/22/2019	4	REHAB	3,009	04/02/2019	LG	100 100
		20	NO PERMIT		09/09/2015	FC	100 100
07-142	07/03/2007	90	BP NVC	11,000	05/12/2008	JH	100 100

LAND

TOTAL	13,939 SF	ZONING	NSD	FRNT	0	ASSESSED	CURRENT	PREVIOUS
Nbhd	NAT'L SEASHORE	NOTE				LAND	340,500	296,100
Inf1	NO ADJ		BUILDING	348,000	299,600			
Inf2	NO ADJ		DETACHED	0	0			
			OTHER	0	0			
						TOTAL	688,500	595,700

DETACHED

TY	QUAL	COND	DIM/NOTE	YB	UNITS	ADJ PRICE	RCNLD

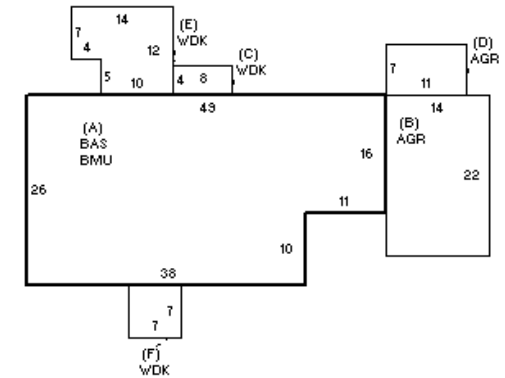

BUILDING

BUILDING	CD	ADJ	DESC	MEASURE	9/9/2015	FC
MODEL	1		RESIDENTIAL	LIST	9/9/2015	EST
STYLE	1	1.00	RANCH [100%]	REVIEW	12/15/2010	MR
QUALITY	A	1.00	AVERAGE [100%]			
FRAME	1	1.00	WOOD FRAME [100%]			

BLDG COMMENTS

LOADING

YEAR BLT	1950	SIZE ADJ	1.040	ELEMENT	CD	DESCRIPTION	ADJ	S	BAT	T	DESCRIPTION	UNITS	YB	ADJ PRICE	RCN	TOTAL RCN	527,266		
NET AREA	1,164	DETAIL ADJ	1.000	FOUNDATION	4	BSMT WALL	1.00	A	BMU	N	BSMT UNFINISHED	1,164		73.20	85,199	CONDITION ELEM	CD		
\$NLA(RCN)	\$453	OVERALL	1.020	EXT. COVER	1	WOOD SHINGLES	1.00	A	BAS	L	BAS AREA	1,164	1950	322.22	375,069				
				ROOF SHAPE	1	GABLE	1.00	+	AGR	N	ATTACHED GARAGE	385		104.59	40,266				
				ROOF COVER	1	ASPHALT SHINGLE	1.00	+	WDK	N	ATT WOOD DECK	229		57.38	13,140				
				FLOOR COVER	1	HARDWOOD	1.00		F11	O	FPL 1S 1OP	1		11,491.60	11,492				
				INT. FINISH	2	DRYWALL	1.00		ODS	O	OUT DOOR SHOWER	1		0.00					
				HEATING/COOLING	2	HOT WATER	1.02												
				FUEL SOURCE	1	OIL	1.00												
CAPACITY		UNITS	ADJ															EFF.YR/AGE	1977 / 45
STORIES(FAR)		1	1.00															COND	34 34 %
ROOMS		0	1.00															FUNC	0
BEDROOMS		3	1.00															ECON	0
BATHROOMS		1	1.00															DEPR	34 % GD 66
FIXTURES		3	\$2,100															RCNLD	\$348,000
UNITS		1	1.00																