

Key: 1074

Town of TRURO - Fiscal Year 2024

9/27/2023 7:11 pm SEQ #: 1.033

LEGAL

LAND

DETACHED

BUILDING

CURRENT OWNER		PARCEL ID		LOCATION	
BOGDOS HARRY L & JOSEPH L Care of: JOSEPH BOGDOS 89 GREENPOINT AVE, UNIT 4B BROOKLYN, NY 11222		36-188-0		26 POND RD	
TRANSFER HISTORY		DOS	T	SALE PRICE	BK-PG (Cert)
BOGDOS HARRY L & JOSEPH L		07/24/2013	A		18582-213
BOGDOS HARRY L&JOAN E&JOS		05/12/2004	99		18582-213
BOGDOS HARRY L & JOAN E		08/17/1994	QS	175,000	9326-018

CLASS	CLASS%	DESCRIPTION			BN ID	BN	CARD	
1010	100	SINGLE FAMILY				1	1 of 1	
PMT NO	PMT DT	TY	DESC	AMOUNT	INSP	BY	1st	%
22-505	12/21/2022	4	REHAB	30,000	01/31/2023	LG	100	100

CD	T	AC/SF/UN	Nbhd	Inf1	Inf2	ADJ BASE	SAF	Inf3	Lpi	VC	CREDIT AMT	ADJ VALUE		
100	A	0.160	11	1.00	1	1.00	1	1.00	630,175	2.99	1	1.00	PF2 1.75	301,890
350	A	0.270	11	1.00	1	1.00	1	1.00	6,900	1.00	1	1.00	TWP 1.00	1,860

TOTAL	18,731 SF	ZONING	RES	FRNT	0	ASSESSED	CURRENT	PREVIOUS
Nbhd	NORTH TRURO	NOTE	PONDFRONT.			LAND	303,800	264,100
Inf1	NO ADJ		BUILDING	337,100	281,900			
Inf2	NO ADJ		DETACHED	800	700			
			OTHER	0	0			
			TOTAL	641,700	546,700			

TY	QUAL	COND	DIM/NOTE	YB	UNITS	ADJ PRICE	RCNLD
SHF	A	1.00	A 0.75 8X8		64	16.47	800

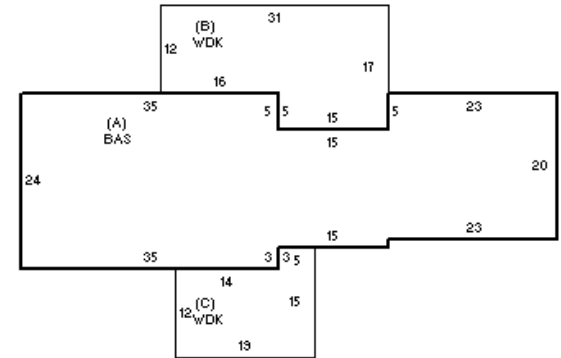

BUILDING	CD	ADJ	DESC	MEASURE	5/11/2016	FC
MODEL	1		RESIDENTIAL	LIST	5/11/2016	FC
STYLE	1	1.00	RANCH [100%]	REVIEW	11/15/2010	MR
QUALITY	A	1.00	AVERAGE [100%]			
FRAME	1	1.00	WOOD FRAME [100%]			

BLDG COMMENTS
PER 2002 LIST, HAS GAS HEATING STOVE in LIVING ROOM.

YEAR BLT	1965	SIZE ADJ	1.020	ELEMENT	CD	DESCRIPTION	ADJ	S	BAT	T	DESCRIPTION	UNITS	YB	ADJ PRICE	RCN	TOTAL RCN	488,530
NET AREA	1,540	DETAIL ADJ	1.000	FOUNDATION	5	OTHER	1.00	A	BAS	L	BAS AREA	1,540	1965	288.57	444,395	CONDITION ELEM	CD
\$NLA(RCN)	\$317	OVERALL	0.950	EXT. COVER	1	WOOD SHINGLES	1.00	+	WDK	N	ATT WOOD DECK	690		43.68	30,138		
CAPACITY				ROOF SHAPE	1	GABLE	1.00	F11	O	O	FPL 1S 10P	1		10,497.20	10,497		
STORIES(FAR)	1	ADJ	1.00	ROOF COVER	1	ASPHALT SHINGLE	1.00										
ROOMS	0		1.00	FLOOR COVER	1	HARDWOOD	1.00										
BEDROOMS	2		1.00	INT. FINISH	2	DRYWALL	1.00										
BATHROOMS	1.5		1.00	HEATING/COOLING	5	ELECTRIC	0.95										
FIXTURES	5		\$3,500	FUEL SOURCE	3	ELECTRIC	1.00										
UNITS	1		1.00														
EFF.YR/AGE																1987 / 35	
COND																31 31 %	
FUNC																0	
ECON																0	
DEPR																31 % GD 69	
RCNLD																\$337,100	