

Key: 1153

Town of TRURO - Fiscal Year 2024

9/27/2023 7:11 pm SEQ #: 1.131

LEGAL

CURRENT OWNER				PARCEL ID				LOCATION			
FALCONER PETER C LIVING TRUST TRS: FALCONER PETER C PO BOX 264 NO TRURO, MA 02652-0264				39-18-0				9 BAY VIEW DR			
TRANSFER HISTORY				DOS	T	SALE PRICE	BK-PG (Cert)				
FALCONER PETER C LIVING T				10/21/2011	99		25774-140				
FALCONER PETER C & MARCIA				10/06/2010	99		24890-158				
FALCONER PETER C				07/10/1997	QS	86,500	10843-247				

CLASS	CLASS%	DESCRIPTION			BN ID	BN	CARD	
1010	100	SINGLE FAMILY				1	1 of 1	
PMT NO	PMT DT	TY	DESC	AMOUNT	INSP	BY	1st	%
FY2018 02-174	09/04/2002	35 1	RES EXEMPT SINGLE FAM R	225,000	10/01/2017 03/07/2004	BT	100	0 100

LAND

CD	T	AC/SF/UN	Nbhd	Inf1	Inf2	ADJ BASE	SAF	Inf3	Lpi	VC	CREDIT AMT	ADJ VALUE
100	A	0.570	11	1.00	1	630,175	1.24	1	1.00	V7	1.75	444,260

TOTAL	24,829 SF	ZONING	RES	FRNT	0	ASSESSED	CURRENT	PREVIOUS
Nbhd	NORTH TRURO	NOTE FY11 VW CHG PER FIELD REV.	LAND	444,300	386,300			
Inf1	NO ADJ		BUILDING	870,300	719,800			
Inf2	NO ADJ		DETACHED	0	0			
			OTHER	0	0			
TOTAL			TOTAL	1,314,600	1,106,100			

DETACHED

TY	QUAL	COND	DIM/NOTE	YB	UNITS	ADJ PRICE	RCNLD

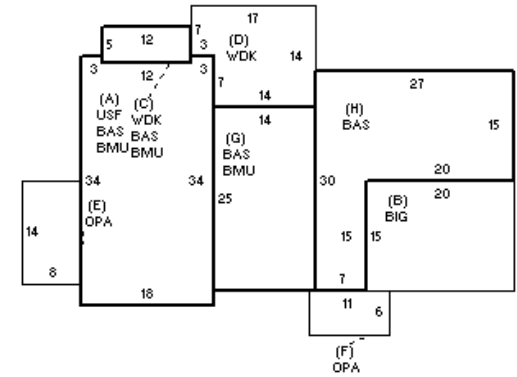

BUILDING

BUILDING	CD	ADJ	DESC	MEASURE	6/14/2021	LG
MODEL	1		RESIDENTIAL	LIST	6/14/2021	LG
STYLE	5	1.05	COLONIAL [100%]	REVIEW	11/15/2010	MR
QUALITY	G	1.35	GOOD [100%]			
FRAME	1	1.00	WOOD FRAME [100%]			

BLDG COMMENTS	6/14/2021 Owner confirmed interior data at door (C-19).
---------------	---

LOADING

YEAR BLT	2002	SIZE ADJ	1.000	ELEMENT	CD	DESCRIPTION	ADJ	S	BAT	T	DESCRIPTION	UNITS	YB	ADJ PRICE	RCN	TOTAL RCN	1,087,893		
NET AREA	2,120	DETAIL ADJ	1.000	FOUNDATION	4	BSMT WALL	1.00	+	BMU	N	BSMT UNFINISHED	1,010		100.60	101,608	CONDITION ELEM	CD		
\$NLA(RCN)	\$513	OVERALL	1.080	EXT. COVER	1	WOOD SHINGLES	1.00	A	USF	L	UP-STRY FIN	600	2002	348.59	209,152				
CAPACITY		UNITS	ADJ	ROOF SHAPE	5	MANSARD	1.00	B	BIG	N	BUILT-IN GARAGE	300		122.62	36,785				
STORIES(FAR)	2	1.00		ROOF COVER	1	ASPHALT SHINGLE	1.00	+	WDK	N	ATT WOOD DECK	277		78.86	21,845				
ROOMS	4	1.00		FLOOR COVER	1	HARDWOOD	1.00	+	OPA	N	OPEN PORCH	178		108.04	19,231				
BEDROOMS	2	1.00		INT. FINISH	2	DRYWALL	1.00	+	BAS	L	BAS AREA	1,520	2002	434.19	659,972				
BATHROOMS	2	1.00		HEATING/COOLING	9	WARM/COOL AIR	1.03	F21	O	FPL 2S 1OP	1			21,937.10	21,937				
FIXTURES	6	\$4,200		FUEL SOURCE	2	GAS	1.00	GFP	O	GAS FIREPLACE	1			13,162.80	13,163				
UNITS	0	1.00																	
																EFF.YR/AGE	2002 / 20		
																COND	20 20 %		
																FUNC	0		
																ECON	0		
																DEPR	20	% GD	80
																RCNLD	\$870,300		