

Key: 1154

Town of TRURO - Fiscal Year 2024

9/27/2023 7:11 pm SEQ #: 1.132

LEGAL

CURRENT OWNER				PARCEL ID				LOCATION			
WALLACE THOMAS J & ANNE F 10 KNOLLWOOD RD WHIPPANY, NJ 07981				39-19-0				14 BAY VIEW DR			
TRANSFER HISTORY				DOS	T	SALE PRICE	BK-PG (Cert)				
WALLACE THOMAS J & ANNE F				05/25/1974	99		2017-200				

CLASS	CLASS%	DESCRIPTION			BN ID	BN	CARD	
1010	100	SINGLE FAMILY				1	1 of 1	
PMT NO	PMT DT	TY	DESC	AMOUNT	INSP	BY	1st	%
03-013	01/28/2003	1	SINGLE FAM R	275,000	04/01/2004	BT	100	100
02-238	11/22/2002	10	ALL OTHERS	10,000	03/20/2003	BT	100	100

LAND

CD	T	AC/SF/UN	Nbhd	Inf1	Inf2	ADJ BASE	SAF	Inf3	Lpi	VC	CREDIT AMT	ADJ VALUE
100	A	0.550	11	1.00	1	522,145	1.27	1	1.00	V4		364,060

DETACHED

TOTAL	23,958 SF	ZONING	RES	FRNT	0	ASSESSED	CURRENT	PREVIOUS
Nbhd	NORTH TRURO	NOTE				LAND	364,100	316,500
Inf1	NO ADJ		BUILDING	782,400	643,100			
Inf2	NO ADJ		DETACHED	0	0			
			OTHER	0	0			
						TOTAL	1,146,500	959,600

TY	QUAL	COND	DIM/NOTE	YB	UNITS	ADJ PRICE	RCNLD

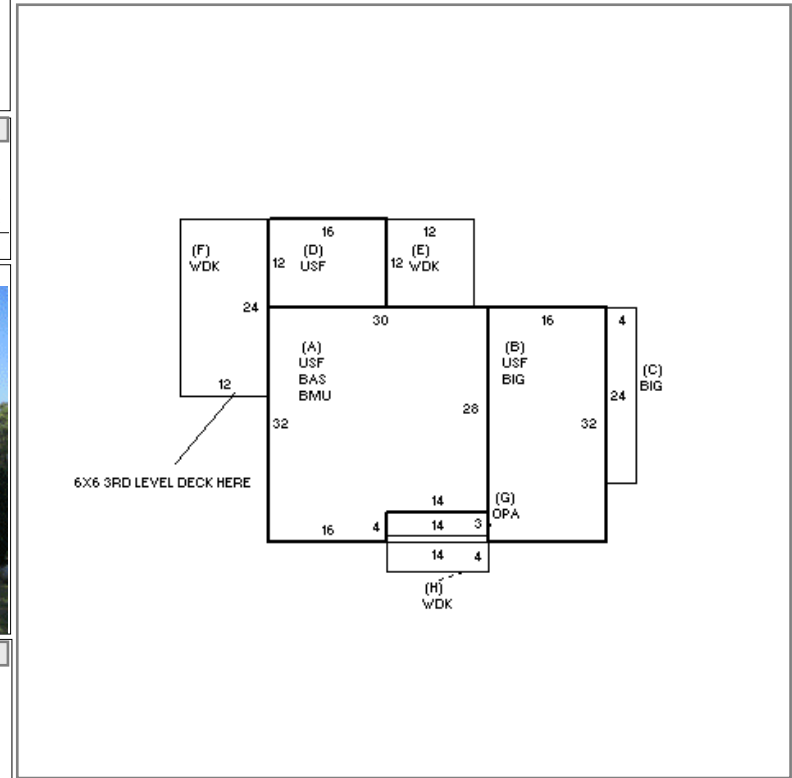

BUILDING

BUILDING	CD	ADJ	DESC	MEASURE	11/18/2022	LG
MODEL	1		RESIDENTIAL	LIST	6/20/2013	FC
STYLE	5	1.05	COLONIAL [100%]	REVIEW	11/15/2010	MR
QUALITY	+	1.15	GOOD-AVE+ [100%]			
FRAME	1	1.00	WOOD FRAME [100%]			

BLDG COMMENTS  
WDK@36 SF=3RD LEVEL DECK.

LOADING

YEAR BLT	2004	SIZE ADJ	0.990	ELEMENT	CD	DESCRIPTION	ADJ	S	BAT	T	DESCRIPTION	UNITS	YB	ADJ PRICE	RCN	TOTAL RCN	954,155
NET AREA	2,512	DETAIL ADJ	1.000	FOUNDATION	4	BSMT WALL	1.00	A	BMU	N	BSMT UNFINISHED	904		87.83	79,400		
\$NLA(RCN)	\$380	OVERALL	1.070	EXT. COVER	1	WOOD SHINGLES	1.00	A	BAS	L	BAS AREA	904	2004	370.03	334,510		
				ROOF SHAPE	1	GABLE	1.00	+	BIG	N	BUILT-IN GARAGE	608		88.11	53,569		
				ROOF COVER	1	ASPHALT SHINGLE	1.00	+	USF	L	UP-STRY FIN	1,608	2004	267.72	430,488		
				FLOOR COVER	1	HARDWOOD	1.00	+	WDK	N	ATT WOOD DECK	488		58.57	28,583		
				INT. FINISH	2	DRYWALL	1.00	G	OPA	N	OPEN PORCH	42		137.77	5,786		
				HEATING/COOLING	2	HOT WATER	1.02	WDK	N	ATT WOOD DECK	36			106.15	3,822		
				FUEL SOURCE	2	GAS	1.00	GFP	O	GAS FIREPLACE	1			10,997.90	10,998		
								ODS	O	OUT DOOR SHOWER	1			0.00			
																EFF.YR/AGE	2004 / 18
																COND	18 18 %
																FUNC	0
																ECON	0
																DEPR	18 % GD 82
																RCNLD	\$782,400