

Key: 1189

Town of TRURO - Fiscal Year 2024

9/27/2023 7:11 pm SEQ #: 1.175

LEGAL

LAND

DETACHED

BUILDING

CURRENT OWNER				PARCEL ID				LOCATION				
HINDSON JAMES F LIV TRST-2012				39-57-0				35 BAY VIEW RD				
TRS: HINDSON JAMES F				TRANSFER HISTORY				DOS	T	SALE PRICE	BK-PG (Cert)	
95 HICKS RD				HINDSON JAMES F LIV TRST-				02/08/2012	A		26066-158	
QUEENSBURY, NY 12804-7309				HINDSON JAMES F				12/13/2006	99		21605-345	
				HINDSON JAMES F & PHILIPP				09/28/1990	QS	525,000	7307-041	

CLASS	CLASS%	DESCRIPTION		BN ID	BN	CARD	
1010	100	SINGLE FAMILY			1	1 of 1	
PMT NO	PMT DT	TY	DESC	AMOUNT	INSP	BY	1st %
17-267X	09/27/2017	3	REPAIR/REMOD	10,667	11/17/2017	LG	100 100
03-102	06/12/2003	3	REPAIR/REMOD	15,000	08/12/2004		100 100
02-105	05/29/2002	10	ALL OTHERS	2,300	03/22/2003	BT	100 100
02-084	04/29/2002	9	DECK	5,000	03/22/2003	BT	100 100

CD	T	AC/SF/UN	Nbhd	Inf1	Inf2	ADJ BASE	SAF	Inf3	Lpi	VC	CREDIT AMT	ADJ VALUE
100	A	0.775	11	1.00	1	2,520,700	1.00	1	1.00	WF2	7.00	1,953,540
300	A	0.345	11	1.00	1	192,500	1.00	1	1.00	WF2	7.00	66,410

TOTAL	1.120 Acres	ZONING	RES	FRNT	0	ASSESSED	CURRENT	PREVIOUS
Nbhd	NORTH TRURO	NOTE				LAND	2,020,000	1,756,300
Inf1	NO ADJ		BUILDING	522,900	431,200			
Inf2	NO ADJ		DETACHED	1,200	1,200			
			OTHER	0	0			
						<b>TOTAL</b>	<b>2,544,100</b>	<b>2,188,700</b>

TY	QUAL	COND	DIM/NOTE	YB	UNITS	ADJ PRICE	RCNLD
BCH	SV	1.00	SV 1.00 STAIRS		1	0.00	
WDK	A	1.00	A 0.75 9*10		90	11.00	700
PTD	A	1.00	A 0.75 IRREG 12*24		288	2.30	500

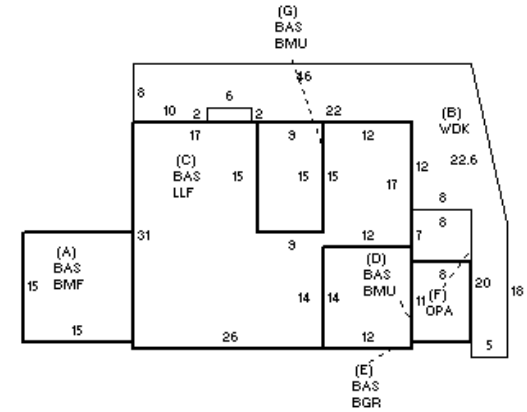

BUILDING	CD	ADJ	DESC	MEASURE	12/7/2022	LG
MODEL	1		RESIDENTIAL	LIST	5/24/2023	LG
STYLE	1	1.00	RANCH [100%]	REVIEW	11/17/2010	MR
QUALITY	A	1.00	AVERAGE [100%]			
FRAME	1	1.00	WOOD FRAME [100%]			

BLDG COMMENTS  
SEC C BSMT=LLF AND UNFINISHED 9x15 BOILER RM).

YEAR BLT	1961	SIZE ADJ	0.995	ELEMENT	CD	DESCRIPTION	ADJ	S	BAT	T	DESCRIPTION	UNITS	YB	ADJ PRICE	RCN	TOTAL RCN	747,034		
NET AREA	2,366	DETAIL ADJ	1.000	FOUNDATION	4	BSMT WALL	1.00	A	BMF	N	BSMT FINISH	225		145.00	32,625	CONDITION ELEM	CD		
\$NLA(RCN)	\$316	OVERALL	1.020	EXT. COVER	1	WOOD SHINGLES	1.00	+	BAS	L	BAS AREA	1,491	1961	302.24	450,636				
				ROOF SHAPE	1	GABLE	1.00	B	WDK	N	ATT WOOD DECK	597		45.75	27,311				
				ROOF COVER	1	ASPHALT SHINGLE	1.00	C	LLF	L	LOWER LEVEL FIN	875	1961	203.39	177,970				
				FLOOR COVER	1	HARDWOOD	1.00	+	BMU	N	BSMT UNFINISHED	223		82.91	18,488				
				INT. FINISH	2	DRYWALL	1.00	E	BGR	N	SF BSMT GARAGE	168		96.71	16,247				
				HEATING/COOLING	2	HOT WATER	1.02	F	OPA	N	OPEN PORCH	56		102.90	5,763				
				FUEL SOURCE	1	OIL	1.00	F11	O	O	FPL 1S 1OP	1		10,994.40	10,994				
																		EFF.YR/AGE	1989 / 33
																		COND	30 30 %
																		FUNC	0
																		ECON	0
																		DEPR	30 % GD 70
																		RCNLD	\$522,900