

Key: 1334

Town of TRURO - Fiscal Year 2024

9/27/2023 7:11 pm SEQ #: 1.343

LEGALS

CURRENT OWNER										PARCEL ID				LOCATION			
GOLDSTEIN MARK & JILL REV TRST TRS: GOLDSTEIN MARK E & JILL A 20 CHURCHILL AVE ARLINGTON, MA 02476										39-213-0				4 DRUNLIN LN			
TRANSFER HISTORY										DOS	T	SALE PRICE	BK-PG (Cert)				
GOLDSTEIN MARK & JILL REV										10/19/2007	99		(184399+)				
GOLDSTEIN MARK & JILL REV										06/11/2007	QS	1,000,000	(183339)				
BECHT LAWRENCE J & JOAN A										07/14/2000	J		(158376)				

CLASS	CLASS%	DESCRIPTION			BN ID	BN	CARD	
1010	100	SINGLE FAMILY				1	1 of 1	
PMT NO	PMT DT	TY	DESC	AMOUNT	INSP	BY	1st	%
CYC	05/26/2023	30	CHECK DATA		03/28/2023	LG	100	100
23-173X	05/09/2023	4	REHAB	17,030		LG	0	0
13-005	01/03/2013	3	REPAIR/REMOD	15,000	12/05/2013	FC	100	100
11-203	10/13/2011	90	BP NVC	8,000	02/28/2012	FC	100	100
10-016	02/09/2010	10	ALL OTHERS	15,000	05/02/2011	MR	100	100

LAND

CD	T	AC/SF/UN	Nbhd	Inf1	Inf2	ADJ BASE	SAF	Inf3	Lpi	VC	CREDIT AMT	ADJ VALUE
100	A	0.775	11A	1.00	1	1,080,300	1.00	1	1.00	V13	3.00	837,230
300	A	0.305	11A	1.00	1	82,500	1.00	1	1.00	V13	3.00	25,160

TOTAL	1.080 Acres	ZONING	RES	FRNT	0	ASSESSED	CURRENT	PREVIOUS
Nbhd	SHEARWATER	NOTE PTD=POOL PATIO.				LAND	862,400	749,800
Inf1	NO ADJ		BUILDING	691,900	535,100			
Inf2	NO ADJ		DETACHED	24,800	22,100			
			OTHER	0	0			
TOTAL			1,579,100	1,307,000				

DETACHED

TY	QUAL	COND	DIM/NOTE	YB	UNITS	ADJ PRICE	RCNLD
SPC	A	1.00	G 0.90 18*32	1993	576	40.27	20,900
SHF	A	1.00	A 0.75 8*12		96	16.47	1,200
PTD	A	1.00	G 0.90 9*32+10*18		558	2.30	1,200
WDK	A	1.00	A 0.75 AT POOL IRRE		180	11.00	1,500

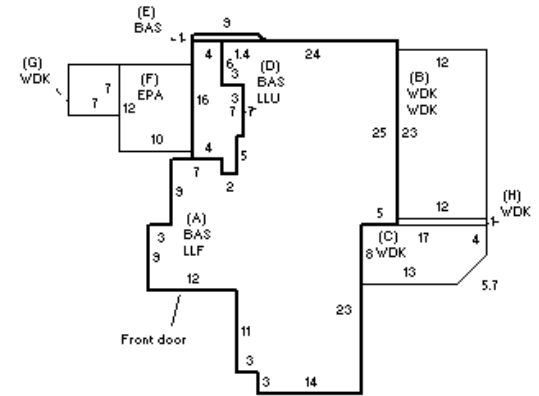

BLDG COMMENTS
LLF=THREE BEDROOMS & TWO FULL BATHS. Minisplits (2) March 2023 CYC - pool area padlocked, no measure.

BUILDING

BUILDING	CD	ADJ	DESC	MEASURE	3/28/2023	LG
MODEL	1		RESIDENTIAL	LIST	7/25/2014	EST
STYLE	8	1.10	CONTEMPORARY [100%]	REVIEW	4/5/2021	MR
QUALITY	G	1.35	GOOD [100%]			
FRAME	1	1.00	WOOD FRAME [100%]			

YEAR BLT	1981	SIZE ADJ	0.995	ELEMENT	CD	DESCRIPTION	ADJ	S	BAT	T	DESCRIPTION	UNITS	YB	ADJ PRICE	RCN	TOTAL RCN	1,002,682
NET AREA	2,349	DETAIL ADJ	1.000	FOUNDATION	4	BSMT WALL	1.00	A	LLF	L	LOWER LEVEL FIN	1,122	1981	293.06	328,818	CONDITION ELEM	CD
\$NLA(RCN)	\$427	OVERALL	1.110	EXT. COVER	1	WOOD SHINGLES	1.00	+	WDK	N	ATT WOOD DECK	741		67.21	49,801		
CAPACITY				ROOF SHAPE	1	GABLE	1.00	D	LLU	N	LOWER LEVEL UNF	95		232.05	22,045		
STORIES(FAR)	1	1.00		ROOF COVER	1	ASPHALT SHINGLE	1.00	+	BAS	L	BAS AREA	1,227	1981	448.46	550,264		
ROOMS	7	1.00		FLOOR COVER	2	SOFTWOOD	1.00	F	EPA	N	ENCL PORCH	120		206.80	24,816		
BEDROOMS	4	1.00		INT. FINISH	2	DRYWALL	1.00	F11	O	FPL 1S 1OP	1		16,152.10	16,152			
BATHROOMS	3	1.00		HEATING/COOLING	19	MINISPLIT W/AC	1.01	MST	O	MASONRY STACK	1		4,486.40	4,486			
FIXTURES	9	\$6,300		FUEL SOURCE	3	ELECTRIC	1.00	ODS	O	OUT DOOR SHOWER	1		0.00				
UNITS	1	1.00															
EFF.YR/AGE																1983 / 39	
COND																31 31 %	
FUNC																0	
ECON																0	
DEPR																31 % GD 69	
RCNLD																\$691,900	