

Key: 1362

Town of TRURO - Fiscal Year 2024

9/27/2023 7:11 pm SEQ #: 1.370

LEGALS

CURRENT OWNER		PARCEL ID		LOCATION	
WOLFERS JUSTIN & STEVENSON BETSEY A 630 GEDDES RIDGE AVENUE ANN ARBOR, MI 48104		39-243-0		7 KESTREL LN	
TRANSFER HISTORY		DOS	T	SALE PRICE	BK-PG (Cert)
		11/08/2013	O	1,635,000	(201977)
		01/11/1991	QS	500,000	(122484)

CLASS	CLASS%	DESCRIPTION		BN ID	BN	CARD	
1010	100	SINGLE FAMILY			1	1 of 1	
PMT NO	PMT DT	TY	DESC	AMOUNT	INSP	BY	1st %
14-067	04/30/2014	3	REPAIR/REMOD	60,000	12/03/2014	FC	100 100
04-045	04/09/2004	9	DECK	5,000	05/20/2005	WL	100 100
00-099	07/01/2000	9	DECK	850	01/01/2001		100 100
92-109	09/23/1992	1	SINGLE FAM R	273,000	03/23/1994		100 100
90-142	11/21/1990	10	ALL OTHERS	20,000	06/07/1993		100 100

LAND

CD	T	AC/SF/UN	Nbhd	Inf1	Inf2	ADJ BASE	SAF	Inf3	Lpi	VC	CREDIT AMT	ADJ VALUE
100	A	0.775	11A	1.00	1	2,520,700	1.00	1.00	WF3	7.00		1,953,540
300	A	0.515	11A	1.00	1	192,500	1.00	1.00	WF3	7.00		99,140

TOTAL	1.290 Acres	ZONING	RES	FRNT	0	ASSESSED	CURRENT	PREVIOUS
Nbhd	SHEARWATER	NOTE				LAND	2,052,700	1,784,700
Inf1	NO ADJ		BUILDING	1,358,400	1,125,100			
Inf2	NO ADJ		DETACHED	0	0			
			OTHER	0	0			
						TOTAL	3,411,100	2,909,800

DETACHED

TY	QUAL	COND	DIM/NOTE	YB	UNITS	ADJ PRICE	RCNLD	PHOTO
								08/24/2020



BUILDING	CD	ADJ	DESC	MEASURE	8/24/2020	LG
MODEL	1		RESIDENTIAL	LIST	8/24/2020	LG
STYLE	8	1.10	CONTEMPORARY [100%]	REVIEW	12/10/2010	MR
QUALITY	G	1.35	GOOD [100%]			
FRAME	1	1.00	WOOD FRAME [100%]			

YEAR BLT	1992	SIZE ADJ	0.975	ELEMENT	CD	DESCRIPTION	ADJ	S	BAT	T	DESCRIPTION	UNITS	YB	ADJ PRICE	RCN
NET AREA	3,931	DETAIL ADJ	1.000	FOUNDATION	4	BSMT WALL	1.00	A	LLF	L	LOWER LEVEL FIN	344	1992	306.80	105,541
\$NLA(RCN)	\$480	OVERALL	1.120	EXT. COVER	1	WOOD SHINGLES	1.00	+	USF	L	UP-STRY FIN	606	1992	348.90	211,433
				ROOF SHAPE	1	GABLE	1.00	+	BGR	N	SF BSMT GARAGE	638		130.92	83,530
				ROOF COVER	1	ASPHALT SHINGLE	1.00	E	BMU	N	BSMT UNFINISHED	752		112.24	84,405
				FLOOR COVER	2	SOFTWOOD	1.00	+	BAS	L	BAS AREA	2,981	1992	412.68	1,230,186
				INT. FINISH	2	DRYWALL	1.00	+	WDK	N	ATT WOOD DECK	1,109		66.45	73,692
				HEATING/COOLING	2	HOT WATER	1.02	+	OPA	N	OPEN PORCH	340		97.74	33,231
				FUEL SOURCE	2	GAS	1.00	N	BMF	N	BSMT FINISH	144		210.62	30,329
									F21	O	FPL 2S 1OP	1		22,180.80	22,181
									MST	O	MASONRY STACK	1		4,435.90	4,436

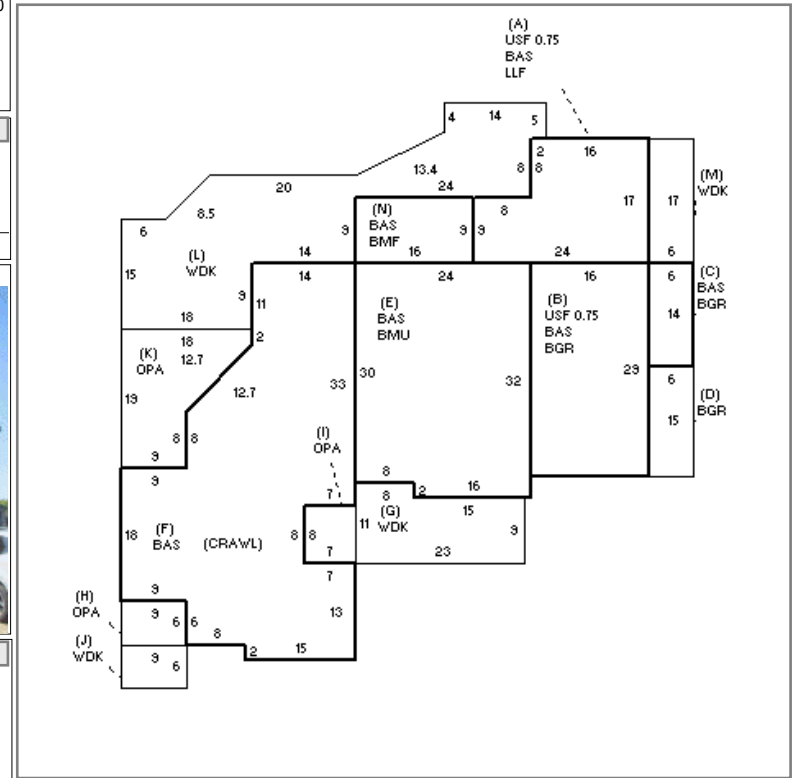

BUILDING

TOTAL RCN	1,886,664
CONDITION ELEM	CD
EFF.YR/AGE	1994 / 28
COND	28 28 %
FUNC	0
ECON	0
DEPR	28 % GD 72
RCNLD	\$1,358,400