

Key: 1384

Town of TRURO - Fiscal Year 2024

9/27/2023 7:11 pm SEQ #: 1.395

LEGAL

CURRENT OWNER		PARCEL ID		LOCATION	
VELIE ASHLEY L & MONAHAN KEVIN 317 16TH ST, APT 28 BROOKLYN, NY 11215		39-265-0		9 DANIEL LN	
TRANSFER HISTORY		DOS	T	SALE PRICE	BK-PG (Cert)
VELIE ASHLEY L & MONAHAN		04/08/2022	QS	840,000	35036-230
COREA BETSI A		02/03/2017	F	1	30280-288
COREA ROBERT B TRUST		01/30/2013	A		27088-53

CLASS	CLASS%	DESCRIPTION		BN ID	BN	CARD	
1010	100	SINGLE FAMILY			1	1 of 1	
PMT NO	PMT DT	TY	DESC	AMOUNT	INSP	BY	1st %
NP	02/16/2023	20	NO PERMIT		02/16/2023	JN	100 100
22-422X	10/31/2022	90	BP NVC	1,900	12/29/2022	LG	100 100
20-143	06/10/2020	80	SOLAR TAXABL	24,000	10/13/2020	LG	100 100
	12/31/2004	30	CHECK DATA		05/08/2007	JH	100 100
		30	CHECK DATA		06/27/2002	BT	100 100

LAND

CD	T	AC/SF/UN	Nbhd	Inf1	Inf2	ADJ BASE	SAF	Inf3	Lpi	VC	CREDIT AMT	ADJ VALUE
100	A	0.775	12	1.00	1	1.00	1	1.00	360,100	1.00	1	1.00
300	A	0.015	12	1.00	1	1.00	1	1.00	27,500	1.00	1	1.00
												279,080
												410

TOTAL	34,413 SF	ZONING	RES	FRNT	0	ASSESSED	CURRENT	PREVIOUS
Nbhd	EAST TRURO	NOTE				LAND	279,500	243,000
Inf1	NO ADJ		BUILDING	549,100	500,800			
Inf2	NO ADJ		DETACHED	0	0			
			OTHER	0	0			
						TOTAL	828,600	743,800

DETACHED

TY	QUAL	COND	DIM/NOTE	YB	UNITS	ADJ PRICE	RCNLD

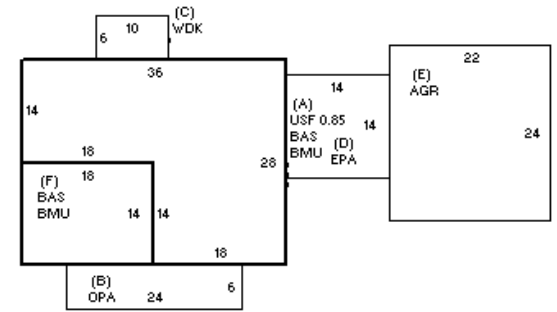

BUILDING

BUILDING	CD	ADJ	DESC	MEASURE	7/6/2020	LG
MODEL	1		RESIDENTIAL	LIST	7/6/2020	LG
STYLE	4	1.10	CAPE [100%]	REVIEW	11/15/2010	MR
QUALITY	A	1.00	AVERAGE [100%]			
FRAME	1	1.00	WOOD FRAME [100%]			

BLDG COMMENTS
7/6/2020 Fam.member confirmed interior data at door (C-19). Wdstove in LR and in breezeway.

INDING

YEAR BLT	1994	SIZE ADJ	1.020	ELEMENT	CD	DESCRIPTION	ADJ	S	BAT	T	DESCRIPTION	UNITS	YB	ADJ PRICE	RCN	TOTAL RCN	742,023
NET AREA	1,651	DETAIL ADJ	1.000	FOUNDATION	4	BSMT WALL	1.00	+	BMU	N	BSMT UNFINISHED	1,008		79.53	80,166	CONDITION ELEM	CD
\$NLA(RCN)	\$449	OVERALL	1.130	EXT. COVER	1	WOOD SHINGLES	1.00	A	BAS	L	BAS AREA	756	1994	350.11	264,683		
				ROOF SHAPE	1	GABLE	1.00	A	USF	L	UP-STRY FIN	643	1994	272.79	175,402		
				ROOF COVER	1	ASPHALT SHINGLE	1.00	B	OPA	N	OPEN PORCH	144		89.90	12,946		
				FLOOR COVER	1	HARDWOOD	1.00	C	WDK	N	ATT WOOD DECK	60		90.06	5,403		
				INT. FINISH	1	PLASTER	1.00	D	EPA	N	ENCL PORCH	196		151.87	29,767		
				HEATING/COOLING	15	FHW/DCTLS AC	1.03	E	AGR	N	ATTACHED GARAGE	528		106.53	56,250		
				FUEL SOURCE	1	OIL	1.00	F	BAS	L	BAS AREA	252	1994	350.11	88,228		
									F21	O	FPL 2S 1OP	1		17,342.00	17,342		
									MST	O	MASONRY STACK	2		3,468.15	6,936		
																EFF.YR/AGE	1996 / 26
																COND	26 26 %
																FUNC	0
																ECON	0
																DEPR	26 % GD 74
																RCNLD	\$549,100