

Key: 1398

Town of TRURO - Fiscal Year 2024

9/27/2023 7:11 pm SEQ #: 1.412

LEGALS

CURRENT OWNER		PARCEL ID		LOCATION	
DONNA M TRAMONTOZZI TRUST & MICHELLE M CHAMBERS TRUST 39 LOCKE ST WATERTOWN, MA 02472		39-279-0		4 KYLE WAY	
TRANSFER HISTORY		DOS	T	SALE PRICE	BK-PG (Cert)
DONNA M TRAMONTOZZI TRUST		11/23/2018	F	1	31682-92
CHAMBERS MICHELLE M & KASPER RICHARD		06/15/1995	QS	160,000	9710-079
		09/26/1989	99	48,400	6894-068

CLASS	CLASS%	DESCRIPTION		BN ID	BN	CARD	
1010	100	SINGLE FAMILY			1	1 of 1	
PMT NO	PMT DT	TY	DESC	AMOUNT	INSP	BY	1st %
91-078	07/29/1991	1	SINGLE FAM R	58,000	08/10/1992		100 100

LAND

CD	T	AC/SF/UN	Nbhd	Inf1	Inf2	ADJ BASE	SAF	Inf3	Lpi	VC	CREDIT AMT	ADJ VALUE
100	A	0.775 12 1.00	RT6	0.90 1	1.00	340,295	1.00 1	1.00	V1	1.05		263,730
300	A	0.055 12 1.00		1 1.00 1	1.00	28,875	1.00 1	1.00	V1	1.05		1,590

TOTAL	36,155 SF	ZONING	RES	FRNT	0	ASSESSED	CURRENT	PREVIOUS
Nbhd	EAST TRURO	N O T E	INFL1=ABUTS ROUTE 6 fy07 minimal view added per nbhd review (no access to 2nd floor wdk).			LAND	265,300	230,700
Inf1	ABUTS RTE 6		BUILDING	392,200	332,800			
Inf2	NO ADJ		DETACHED	0	0			
			OTHER	0	0			
			TOTAL	657,500	563,500			

DETACHED

TY	QUAL	COND	DIM/NOTE	YB	UNITS	ADJ PRICE	RCNLD	PHOTO
								07/17/2012
								

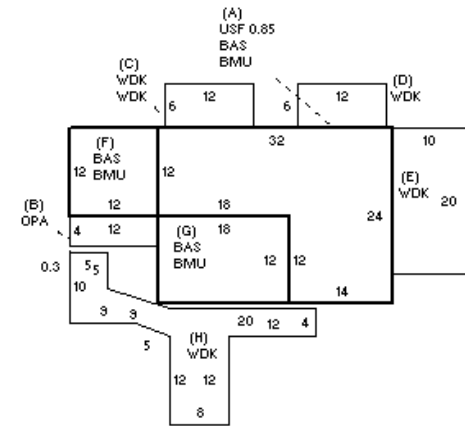

BUILDING

BUILDING	CD	ADJ	DESC	MEASURE	8/18/2020	LG
MODEL	1		RESIDENTIAL	LIST	8/18/2020	LG
STYLE	4	1.10	CAPE [100%]	REVIEW	11/15/2010	MR
QUALITY	A	1.00	AVERAGE [100%]	8/18/2020 Owner confirmed interior data at door (C-19).		
FRAME	1	1.00	WOOD FRAME [100%]			

G

YEAR BLT	1991	SIZE ADJ	1.030	ELEMENT	CD	DESCRIPTION	ADJ	S	BAT	T	DESCRIPTION	UNITS	YB	ADJ PRICE	RCN	TOTAL RCN	560,238
NET AREA	1,381	DETAIL ADJ	1.000	FOUNDATION			1.00	+	BMU	N	BSMT UNFINISHED	912		81.69	74,500	CONDITION ELEM	CD
\$NLA(RCN)	\$406	OVERALL	1.100	EXT. COVER	1	WOOD SHINGLES	1.00	+	BAS	L	BAS AREA	696	1991	344.16	239,532		
CAPACITY		UNITS	ADJ	ROOF SHAPE	1	GABLE	1.00	A	USF	L	UP-STRY FIN	469	1991	270.88	127,044		
STORIES(FAR)		1.75	1.00	ROOF COVER	1	ASPHALT SHINGLE	1.00	B	OPA	N	OPEN PORCH	48		128.15	6,151		
ROOMS		5	1.00	FLOOR COVER	1	HARDWOOD	1.00	+	WDK	N	ATT WOOD DECK	675		51.07	34,473		
BEDROOMS		3	1.00	INT. FINISH	2	DRYWALL	1.00	G	BAS	L	BAS AREA	216	1991	344.15	74,337		
BATHROOMS		2	1.00	HEATING/COOLING	1	FORCED AIR	1.00		ODS	O	OUT DOOR SHOWER			0.00			
FIXTURES		6	\$4,200	FUEL SOURCE	2	GAS	1.00										
UNITS		0	1.00														
																EFF.YR/AGE	1991 / 31
																COND	30 30 %
																FUNC	0
																ECON	0
																DEPR	30 % GD 70
																RCNLD	\$392,200