

Key: 1466

Town of TRURO - Fiscal Year 2024

9/27/2023 7:11 pm SEQ #: 1.478

LEGALS

CURRENT OWNER				PARCEL ID				LOCATION			
MAIER WILMA K LIFE ESTATE RMNDR: MAIER CAPE COD TRUST C/O VAGLIARDO KAREN M 1 MOHICAN CIRCLE ONEONTA, NY 13820				40-41-0				7 MOSES WAY			
TRANSFER HISTORY				DOS	T	SALE PRICE	BK-PG (Cert)				
MAIER WILMA K LIFE ESTATE				08/30/2005	99		20208-44				
MAIER WILMA K				08/30/2005	99		20208-42				
MAIER JOHN & WILMA				01/10/1985	99		4379-051				

CLASS	CLASS%	DESCRIPTION			BN ID	BN	CARD	
1010	100	SINGLE FAMILY				1	1 of 1	
PMT NO	PMT DT	TY	DESC	AMOUNT	INSP	BY	1st	%

LAND

CD	T	AC/SF/UN	Nbhd	Infl1	Infl2	ADJ BASE	SAF	Infl3	Lpi	VC	CREDIT AMT	ADJ VALUE
100	A	0.540	12	1.00	1	360,100	1.28	1	1.00	R04	1.00	249,680

TOTAL	23,522 SF	ZONING	RES	FRNT	0	ASSESSED	CURRENT	PREVIOUS
Nbhd	EAST TRURO	NOTE				LAND	249,700	217,100
Infl1	NO ADJ		BUILDING	379,000	321,600			
Infl2	NO ADJ		DETACHED	1,700	1,600			
			OTHER	0	0			
						TOTAL	630,400	540,300

DETACHED

TY	QUAL	COND	DIM/NOTE	YB	UNITS	ADJ PRICE	RCNLD	PHOTO
WDK	G	1.18 G	0.90 12*12		144	12.98	1,700	05/22/2018



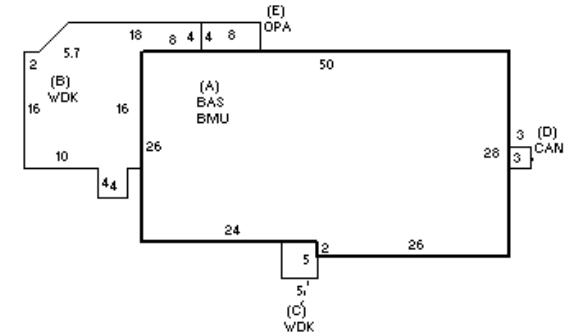

BUILDING

BUILDING	CD	ADJ	DESC	MEASURE	5/22/2018	LG
MODEL	1		RESIDENTIAL	LIST	9/3/2009	EST
STYLE	1	1.00	RANCH [100%]	REVIEW	11/15/2010	MR
QUALITY	A	1.00	AVERAGE [100%]			
FRAME	1	1.00	WOOD FRAME [100%]			

YEAR BLT	1974	SIZE ADJ	1.030	ELEMENT	CD	DESCRIPTION	ADJ	S	BAT	T	DESCRIPTION	UNITS	YB	ADJ PRICE	RCN	TOTAL RCN	557,414
NET AREA	1,352	DETAIL ADJ	1.000	FOUNDATION			1.00	A	BMU	N	BSMT UNFINISHED	1,352		68.40	92,471		
\$NLA(RCN)	\$412	OVERALL	1.000	EXT. COVER	1	WOOD SHINGLES	1.00	A	BAS	L	BAS AREA	1,352	1974	309.80	418,852		
				ROOF SHAPE	1	GABLE	1.00	+	WDK	N	ATT WOOD DECK	377		52.62	19,837		
				ROOF COVER	1	ASPHALT SHINGLE	1.00	D	CAN	N	CANOPY	9		47.72	430		
				FLOOR COVER	99	N/A	1.00	E	OPA	N	OPEN PORCH	32		116.49	3,728		
				INT. FINISH	2	DRYWALL	1.00		BMG	O	BSMT GARAGE	1		7,438.70	7,439		
				HEATING/COOLING	1	FORCED AIR	1.00		F11	O	FPL 1S 1OP	1		11,158.00	11,158		
				FUEL SOURCE	1	OIL	1.00										

TOTAL RCN	557,414
CONDITION ELEM	CD
EFF.YR/AGE	1981 / 41
COND	32 32 %
FUNC	0
ECON	0
DEPR	32 % GD 68
RCNLD	\$379,000