

Key: 1591

Town of TRURO - Fiscal Year 2024

9/27/2023 7:11 pm SEQ #: 1.595

LEG
AL
LAND

CURRENT OWNER		PARCEL ID	LOCATION			
19 CRESTVIEW CIRCLE RLTY TRUST TRS: SMALL PETER M & CARLA E C/O SMALL CARLA E 3 HELEN RD NEEDHAM, MA 02492		42-19-0	19 CRESTVIEW CIR			
TRANSFER HISTORY		DOS	T	SALE PRICE	BK-PG (Cert)	
19 CRESTVIEW CIRCLE RLTY		12/18/2008	99		23322-268	
SMALL PARKER A JR QPR TRU		08/21/2007	99		10380-240+	
SMALL PARKER A JR QPR TRU		09/11/1996	F		10380-253+	

CLASS	CLASS%	DESCRIPTION			BN ID	BN	CARD	
1010	100	SINGLE FAMILY				1	1 of 1	
PMT NO	PMT DT	TY	DESC	AMOUNT	INSP	BY	1st	%
10-261	12/20/2010	10	ALL OTHERS	165,000	03/09/2012	FC	100	100
93-139	11/10/1993	1	SINGLE FAM R	240,000	04/27/1994		100	100

LAND

CD	T	AC/SF/UN	Nbhd	Infl1	Infl2	ADJ BASE	SAF	Infl3	Lpi	VC	CREDIT AMT	ADJ VALUE
100	A	0.775	11	1.00	1	2,520,700	1.00	1	1.00	WF2	7.00	1,953,540
300	A	0.545	11	1.00	1	192,500	1.00	1	1.00	WF2	7.00	104,910

TOTAL	1.320 Acres	ZONING	RES	FRNT	0	ASSESSED	CURRENT	PREVIOUS
Nbhd	NORTH TRURO	NOTE				LAND	2,058,500	1,789,800
Infl1	NO ADJ		BUILDING	879,100	728,500			
Infl2	NO ADJ		DETACHED	0	0			
			OTHER	0	0			
						TOTAL	2,937,600	2,518,300

DETACHED

TY	QUAL	COND	DIM/NOTE	YB	UNITS	ADJ PRICE	RCNLD

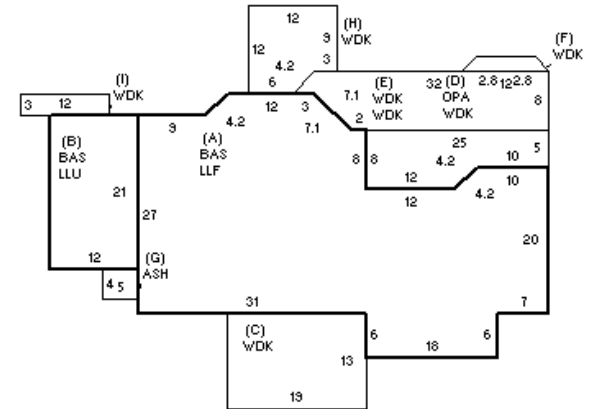

BUILDING

BUILDING	CD	ADJ	DESC	MEASURE	4/6/2018	LG
MODEL	1		RESIDENTIAL	LIST	4/23/2018	LG
STYLE	1	1.00	RANCH [100%]	REVIEW	4/5/2021	MR
QUALITY	G	1.35	GOOD [100%]			
FRAME	1	1.00	WOOD FRAME [100%]			

BLDG COMMENTS

INDING

YEAR BLT	1993	SIZE ADJ	0.980
NET AREA	3,140	DETAIL ADJ	1.000
\$NLA(RCN)	\$389	OVERALL	1.020
CAPACITY		UNITS	ADJ
STORIES(FAR)		0	1.00
ROOMS		10	1.00
BEDROOMS		6	1.00
BATHROOMS		4	1.00
FIXTURES		12	\$8,400
UNITS		0	1.00

ELEMENT	CD	DESCRIPTION	ADJ
FOUNDATION			1.00
EXT. COVER	1	WOOD SHINGLES	1.00
ROOF SHAPE	1	GABLE	1.00
ROOF COVER	1	ASPHALT SHINGLE	1.00
FLOOR COVER	2	SOFTWOOD	1.00
INT. FINISH	2	DRYWALL	1.00
HEATING/COOLING	2	HOT WATER	1.02
FUEL SOURCE	1	OIL	1.00

S	BAT	T	DESCRIPTION	UNITS	YB	ADJ PRICE	RCN
A	LLF	L	LOWER LEVEL FIN	1,444	1993	260.04	375,499
+	BAS	L	BAS AREA	1,696	1993	395.84	671,347
B	LLU	N	LOWER LEVEL UNF	252		210.01	52,923
+	WDK	N	ATT WOOD DECK	1,096		60.83	66,666
D	OPA	N	OPEN PORCH	166		100.00	16,600
G	ASH	N	ATT SHED	20		56.54	1,131
F22	O		FPL 2S 2OP	1		28,425.00	28,425
ODS	O		OUT DOOR SHOWER			0.00	

TOTAL RCN	1,220,991
CONDITION ELEM	CD
EFF.YR/AGE	1994 / 28
COND	28 28 %
FUNC	0
ECON	0
DEPR	28 % GD 72
RCNLD	\$879,100