

Key: 1610

Town of TRURO - Fiscal Year 2024

9/27/2023 7:11 pm SEQ #: 1.616

LEGALS

CURRENT OWNER		PARCEL ID		LOCATION	
CREST VIEW HOLDINGS LLC MGR: SHANNON WU 43 5TH AVE, APT 6W NEW YORK, NY 10003		42-39-0		21 CRESTVIEW CIR	
TRANSFER HISTORY		DOS	T	SALE PRICE	BK-PG (Cert)
CREST VIEW HOLDINGS LLC		03/26/2019	QS	4,250,000	31910-118
SASCO FARMS CAPE COD LLC		10/11/2013	N		27752-156
ESSE TODD		11/09/2012	F		26840-269

LAND

CD	T	AC/SF/UN	Nbhd	Inf1	Inf2	ADJ BASE	SAF	Inf3	Lpi	VC	CREDIT AMT	ADJ VALUE
100	A	0.775	11	1.00	1	2,520,700	1.00	1	1.00	WF2	7.00	1,953,540
300	A	0.485	11	1.00	1	192,500	1.00	1	1.00	WF2	7.00	93,360

TOTAL	1.260 Acres	ZONING	RES	FRNT	0	ASSESSED	CURRENT	PREVIOUS
Nbhd	NORTH TRURO	NOTE				LAND	2,046,900	1,779,700
Inf1	NO ADJ		BUILDING	3,204,600	2,747,300			
Inf2	NO ADJ		DETACHED	62,100	59,200			
			OTHER	0	0			
						TOTAL	5,313,600	4,586,200

DETACHED

TY	QUAL	COND	DIM/NOTE	YB	UNITS	ADJ PRICE	RCNLD
BCH	SV	1.00	SV 1.00 BEACH STAIRS	1994	1	0.00	
SPC	E	1.80	G+ 0.95 REFLECTING P	2010	396	91.70	34,500
DGF	E	1.80	E 1.00 30*24	2011	720	38.28	27,600



BUILDING

BUILDING	CD	ADJ	DESC	MEASURE	11/17/2020	LG
MODEL	1		RESIDENTIAL	LIST	5/6/2011	MR
STYLE	8	1.10	CONTEMPORARY [100%]	REVIEW	4/5/2021	MR
QUALITY	E	2.00	EXCELLENT [100%]			
FRAME	1	1.00	WOOD FRAME [100%]			

BLDG COMMENTS		

CLASS	CLASS%	DESCRIPTION		BN ID	BN	CARD	
1010	100	SINGLE FAMILY			1	1 of 1	
PMT NO	PMT DT	TY	DESC	AMOUNT	INSP	BY	1st %
20-227	08/24/2020	80	SOLAR TAXABL	115,854	11/17/2020	LG	100 100
10-013	02/08/2010	1	SINGLE FAM R	2,300,000	10/24/2012	FC	100 100
94-90	07/28/1994	10	ALL OTHERS	13,800	09/05/1995		100 100

EXT COVER=REDWOOD

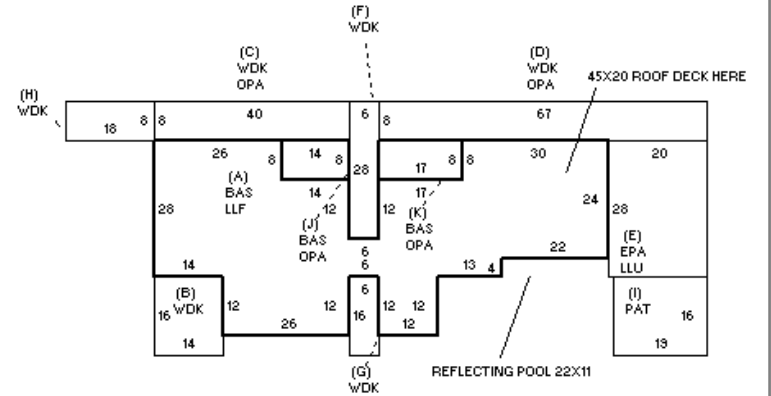

LOADING

YEAR BLT	2010	SIZE ADJ	0.950	ELEMENT	CD	DESCRIPTION	ADJ	S	BAT	T	DESCRIPTION	UNITS	YB	ADJ PRICE	RCN	TOTAL RCN	3,521,509		
NET AREA	5,456	DETAIL ADJ	1.000	FOUNDATION	3	CONTIN WALL	1.00	A	LLF	L	LOWER LEVEL FIN	2,604	2010	388.90	1,012,703	CONDITION ELEM	CD		
\$NLA(RCN)	\$645	OVERALL	1.130	EXT. COVER	14	OTHER	1.00	+	BAS	L	BAS AREA	2,852	2010	601.01	1,714,092				
CAPACITY				ROOF SHAPE	4	FLAT/SHED	1.00	+	WDK	N	ATT WOOD DECK	1,488		96.78	144,004				
STORIES(FAR)	1		1.00	ROOF COVER	7	ROLL	1.00	+	OPA	N	OPEN PORCH	1,104		125.60	138,662				
ROOMS	10		1.00	FLOOR COVER	1	HARDWOOD	1.00	E	LLU	N	LOWER LEVEL UNF	560		334.13	187,115				
BEDROOMS	4		1.00	INT. FINISH	2	DRYWALL	1.00	E	EPA	N	ENCL PORCH	560		223.34	125,071				
BATHROOMS	5.5		1.00	HEATING/COOLING	9	WARM/COOL AIR	1.03	I	PAT	N	PATIO	304		31.94	9,709				
FIXTURES	18	\$12,600		FUEL SOURCE	2	GAS	1.00		WDK	N	ATT WOOD DECK	900		96.78	87,100				
UNITS	1		1.00						F12	O	FPL 1S 2OP	1		32,303.80	32,304				
												GFP	O	GAS FIREPLACE	3	19,383.10	58,149		
												ODS	O	OUT DOOR SHOWER	1	0.00			
																EFF.YR/AGE	2013 / 9		
																COND	09 09 %		
																FUNC	0		
																ECON	0		
																DEPR	9 % GD 91		
																RCNLD	\$3,204,600		