

Key: 163

Town of TRURO - Fiscal Year 2024

9/27/2023 7:11 pm SEQ #: 103

LEGAL

CURRENT OWNER				PARCEL ID				LOCATION							
WATERHOUSE REALTY TRUST				3-8-0				599 SHORE RD							
TRS: WATERHOUSE DAVID N& IRENE				TRANSFER HISTORY				DOS	T	SALE PRICE	BK-PG (Cert)				
C/O WATERHOUSE TIM				WATERHOUSE REALTY TRUST				12/02/1993	99		8922-259				
115 MATTHEWS DR															
WENTZVILLE, MO 63385															

CLASS	CLASS%	DESCRIPTION				BN ID	BN	CARD	
1010	100	SINGLE FAMILY					1	1 of 1	
PMT NO	PMT DT	TY	DESC	AMOUNT	INSP	BY	1st	%	

LAND

CD	T	AC/SF/UN	Nbhd	Inf1	Inf2	ADJ BASE	SAF	Inf3	Lpi	VC	CREDIT AMT	ADJ VALUE	
100	A	0.240	10	1.00	1	1.00	630,175	2.26	1	1.00	V7	1.75	341,280

TOTAL	10,454 SF	ZONING	LBP	FRNT	0	ASSESSED	CURRENT	PREVIOUS
Nbhd	BEACH POINT	N O T E	BACKS UP TO RT 6. FY11=ADDED VW (LAKE+OBSTRUCTED BAY) PER FIELD REV.			LAND	341,300	296,700
Inf1	NO ADJ		BUILDING	466,700	396,000			
Inf2	NO ADJ		DETACHED	0	0			
			OTHER	0	0			
TOTAL						808,000	692,700	

DETAILED

TY	QUAL	COND	DIM/NOTE	YB	UNITS	ADJ PRICE	RCNLD

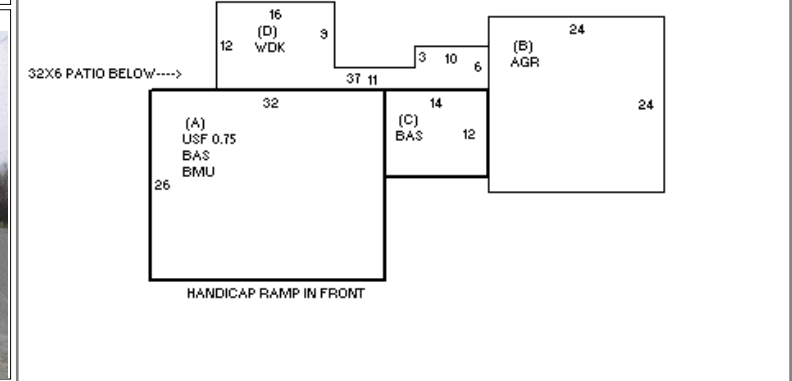

BUILDING

BUILDING	CD	ADJ	DESC	MEASURE	4/26/2017	LG
MODEL	1		RESIDENTIAL	LIST	6/30/2009	EST
STYLE	4	1.10	CAPE [100%]	REVIEW	11/10/2010	MR
QUALITY	A	1.00	AVERAGE [100%]			
FRAME	1	1.00	WOOD FRAME [100%]			

BLDG COMMENTS

YEAR BLT	1971	SIZE ADJ	1.020	ELEMENT	CD	DESCRIPTION	ADJ	S	BAT	T	DESCRIPTION	UNITS	YB	ADJ PRICE	RCN	TOTAL RCN	686,368	
NET AREA	1,624	DETAIL ADJ	1.000	FOUNDATION			1.00	A	BMU	N	BSMT UNFINISHED	832		82.37	68,529	CONDITION ELEM	CD	
\$NLA(RCN)	\$423	OVERALL	1.120	EXT. COVER	1	WOOD SHINGLES	1.00	A	USF	L	UP-STRY FIN	624	1971	270.37	168,712			
CAPACITY			UNITS	ADJ	ROOF SHAPE	1	GABLE	1.00	B	AGR	N	ATTACHED GARAGE	576	103.25	59,470			
STORIES(FAR)	1.75	1.00	ROOF COVER	1	ASPHALT SHINGLE	1.00	+	BAS	L	BAS AREA	1,000	1971	347.01	347,011				
ROOMS	0	1.00	FLOOR COVER	3	W/W CARPET	1.00	D	WDK	N	ATT WOOD DECK	285		61.79	17,611				
BEDROOMS	3	1.00	INT. FINISH	2	DRYWALL	1.00		PAT	N	PATIO	192		18.99	3,647				
BATHROOMS	2	1.00	HEATING/COOLING	3	RADIANT	1.02		F21	O	FPL 2S 1OP	1		17,188.60	17,189				
FIXTURES	6	\$4,200	FUEL SOURCE	3	ELECTRIC	1.00												
UNITS	0	1.00																
																EFF.YR/AGE	1979 / 43	
																COND	32 32 %	
																FUNC	0	
																ECON	0	
																DEPR	32 % GD 68	
																RCNLD	\$466,700	