

Key: 1640

Town of TRURO - Fiscal Year 2024

9/27/2023 7:11 pm SEQ #: 1.648

LEGAL

CURRENT OWNER				PARCEL ID				LOCATION					
JOHNSON ROBERT W & JOHNSON CHRISTOPHER R 25 SARLES ST ARMONK, NY 10504-1230				42-69-0				15 FISHERMANS RD					
				TRANSFER HISTORY				DOS	T	SALE PRICE		BK-PG (Cert)	
				JOHNSON ROBERT W & JOHNSON KENNETH B & FLORE				05/22/2018	H	1 (49164)		1 (49164)	
				08/07/1970	99								

CLASS	CLASS%	DESCRIPTION			BN ID	BN	CARD	
1010	100	SINGLE FAMILY				1	1 of 1	
PMT NO	PMT DT	TY	DESC	AMOUNT	INSP	BY	1st	%
16-254	10/25/2016	3	REPAIR/REMOD	15,000	01/17/2017	LG	100	100
16-063	04/06/2016	90	BP NVC	10,000	01/17/2017	LG	100	100
15-304	12/08/2015	90	BP NVC	10,000	01/08/2016	JN	100	100

LAND

CD	T	AC/SF/UN	Nbhd	Inf1	Inf2	ADJ BASE	SAF	Inf3	Lpi	VC	CREDIT AMT	ADJ VALUE
100	A	0.770	11	1.00	1	1.00	1	1.00	R07	1.60		445,640

DETACHED

TOTAL	33,541 SF	ZONING	RES	FRNT	0	ASSESSED	CURRENT	PREVIOUS
Nbhd	NORTH TRURO	NOTE			LAND	445,600	387,500	
Inf1	NO ADJ		BUILDING	508,100	431,100			
Inf2	NO ADJ		DETACHED	0	0			
			OTHER	0	0			
		TOTAL	953,700	818,600				

TY	QUAL	COND	DIM/NOTE	YB	UNITS	ADJ PRICE	RCNLD

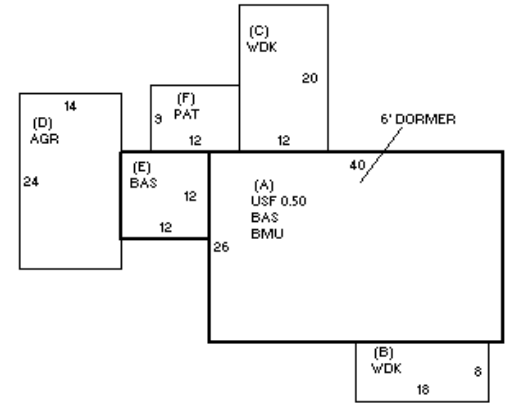

BUILDING

BUILDING	CD	ADJ	DESC	MEASURE	1/17/2017	LG
MODEL	1		RESIDENTIAL	LIST	1/27/2017	LG
STYLE	4	1.10	CAPE [100%]	REVIEW	11/22/2010	MR
QUALITY	A	1.00	AVERAGE [100%]			
FRAME	1	1.00	WOOD FRAME [100%]			

BLDG COMMENTS

BUILDING

YEAR BLT	1971	SIZE ADJ	1.020	ELEMENT	CD	DESCRIPTION	ADJ	S	BAT	T	DESCRIPTION	UNITS	YB	ADJ PRICE	RCN	TOTAL RCN	725,844
NET AREA	1,704	DETAIL ADJ	1.000	FOUNDATION			1.00	A	BMU	N	BSMT UNFINISHED	1,040		79.53	82,711		
\$NLA(RCN)	\$426	OVERALL	1.130	EXT. COVER	1	WOOD SHINGLES	1.00	A	BAS	L	BAS AREA	1,040	1971	350.11	364,113		
				ROOF SHAPE	1	GABLE	1.00	A	USF	L	UP-STRY FIN	520	1971	275.57	143,296		
				ROOF COVER	1	ASPHALT SHINGLE	1.00	+	WDK	N	ATT WOOD DECK	384		58.88	22,611		
				FLOOR COVER	3	W/W CARPET	1.00	D	AGR	N	ATTACHED GARAGE	336		116.00	38,978		
				INT. FINISH	3	WOOD PANEL	1.00	E	BAS	L	BAS AREA	144	1979	350.11	50,416		
				HEATING/COOLING	9	WARM/COOL AIR	1.03	F	PAT	N	PATIO	108		20.17	2,178		
				FUEL SOURCE	1	OIL	1.00	F21	O		FPL 2S 10P	1		17,342.00	17,342		
																EFF.YR/AGE	1990 / 32
																COND	30 30 %
																FUNC	0
																ECON	0
																DEPR	30 % GD 70
																RCNLD	\$508,100