

Key: 1652

Town of TRURO - Fiscal Year 2024

9/27/2023 7:11 pm SEQ #: 1.660

LEGALS

CURRENT OWNER						PARCEL ID				LOCATION			
CASTRO GONZALO V (LIFE EST) RMNDR: CASTRO NORA M 1992 TR 1 MUSTER CT LEXINGTON, MA 02420						42-81-0				30 FISHERMANS RD			
TRANSFER HISTORY						DOS	T	SALE PRICE	BK-PG (Cert)				
CASTRO GONZALO V (LIFE ES						08/16/2013	H		(201191)				
CASTRO NORA M ESTATE OF						03/29/2006	99		(148139+)				
CASTRO NORA M						04/15/1998	P	134,750	(148139)				

CLASS	CLASS%	DESCRIPTION			BN ID	BN	CARD	
1010	100	SINGLE FAMILY				1	1 of 1	
PMT NO	PMT DT	TY	DESC	AMOUNT	INSP	BY	1st	%
98-212	11/01/1998	1	SINGLE FAM R	210,000	01/01/2000		100	100
98-185	10/01/1998	10	ALL OTHERS	15,000	01/01/1999		100	100

LAND

CD	T	AC/SF/UN	Nbhd	Inf1	Inf2	ADJ BASE	SAF	Inf3	Lpi	VC	CREDIT AMT	ADJ VALUE				
100	A	0.640	11	1.00	1	1.00	1	1.00	630,175	1.14	1	1.00	V7	1.75		460,340

DETACHED

TOTAL	27,878 SF	ZONING	RES	FRNT	0	ASSESSED	CURRENT	PREVIOUS
Nbhd	NORTH TRURO	NOTE				LAND	460,300	400,300
Inf1	NO ADJ		BUILDING	785,500	650,300			
Inf2	NO ADJ		DETACHED	0	0			
			OTHER	0	0			
						TOTAL	1,245,800	1,050,600

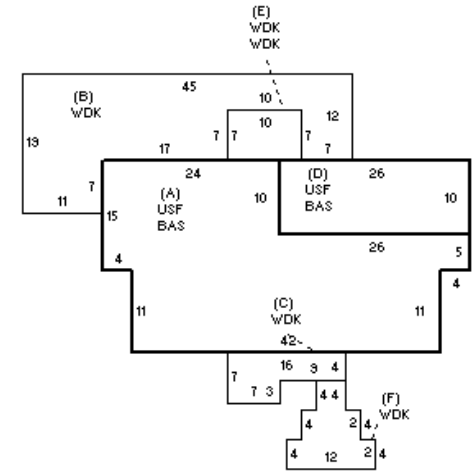

BUILDING

TY	QUAL	COND	DIM/NOTE	YB	UNITS	ADJ PRICE	RCNLD



PHOTO	05/23/2017
BLDG COMMENTS	
FY11 CHGS PER 9/09 M+L.	

INSTALL

BUILDING	CD	ADJ	DESC	MEASURE	5/23/2017	LG								TOTAL RCN	1,033,549											
MODEL	1		RESIDENTIAL	LIST	6/22/2017	LG	YEAR BLT	1998	SIZE ADJ	0.995	ELEMENT	CD	DESCRIPTION	ADJ	S	BAT	T	DESCRIPTION	UNITS	YB	ADJ PRICE	RCN	TOTAL RCN	CONDITION ELEM	CD	
STYLE	8	1.10	CONTEMPORARY [100%]	REVIEW	11/22/2010	MR	NET AREA	2,424	DETAIL ADJ	1.000	FOUNDATION			1.00	+	BAS	L	BAS AREA	1,212	1998	452.50	548,433				
QUALITY	G	1.35	GOOD [100%]				\$NLA(RCN)	\$426	OVERALL	1.120	EXT. COVER	1	WOOD SHINGLES	1.00	+	USF	L	UP-STRY FIN	1,212	1998	343.34	416,128				
FRAME	1	1.00	WOOD FRAME [100%]				CAPACITY																			
							STORIES(FAR)	2		1.00	ROOF SHAPE	1	GABLE	1.00	+	WDK	N	ATT WOOD DECK	868		67.81	58,861				
							ROOMS	6		1.00	ROOF COVER	1	ASPALT SHINGLE	1.00	MST	O	MASONRY STACK	1		4,526.90		4,527				
							BEDROOMS	3		1.00	FLOOR COVER	1	HARDWOOD	1.00	ODS	O	OUT DOOR SHOWER			0.00						
							BATHROOMS	2		1.00	INT. FINISH	2	DRYWALL	1.00												
							FIXTURES	8	\$5,600		HEATING/COOLING	2	HOT WATER	1.02												
							UNITS	0	1.00		FUEL SOURCE	2	GAS	1.00												
																							EFF.YR/AGE	1998 / 24		
																							COND	24 24 %		
																							FUNC	0		
																							ECON	0		
																							DEPR	24 % GD 76		
																							RCNLD	\$785,500		