

Key: 1661

Town of TRURO - Fiscal Year 2024

9/27/2023 7:11 pm SEQ #: 1.669

LEGAL

| CURRENT OWNER | | PARCEL ID | | LOCATION | |
|---|--|------------|----|---------------|--------------|
| WEILBURG JEFFREY B & BARBARA R 177 PARK ST NEWTON, MA 02458 | | 42-90-0 | | 1 BAYBERRY RD | |
| TRANSFER HISTORY | | DOS | T | SALE PRICE | BK-PG (Cert) |
| WEILBURG JEFFREY B & BARB | | 07/01/2008 | QS | 525,000 | (186374) |
| HERMANN RICHARD C & | | 07/25/2003 | QS | 520,000 | (169957) |
| BRADSHAW LILLIAN | | 07/25/2003 | 99 | | (77742) |

| CLASS | CLASS% | DESCRIPTION | | BN ID | BN | CARD | |
|--------|------------|---------------|--------|--------|------------|--------|---------|
| 1010 | 100 | SINGLE FAMILY | | | 1 | 1 of 1 | |
| PMT NO | PMT DT | TY | DESC | AMOUNT | INSP | BY | 1st % |
| 08-117 | 06/04/2008 | 90 | BP NVC | 900 | 09/08/2009 | FC | 100 100 |
| 07-138 | 06/29/2007 | 90 | BP NVC | 1,500 | 05/16/2008 | JH | 100 100 |
| 04-068 | 05/19/2004 | 90 | BP NVC | 6,500 | 05/10/2007 | JH | 100 100 |

LAND

| CD | T | AC/SF/UN | Nbhd | Inf1 | Inf2 | ADJ BASE | SAF | Inf3 | Lpi | VC | CREDIT AMT | ADJ VALUE | | | | |
|-----|---|----------|------|------|------|----------|-----|------|---------|------|------------|-----------|-----|------|--|---------|
| 100 | A | 0.775 | 11 | 1.00 | 70 | 0.70 | 1 | 1.00 | 403,312 | 1.00 | 1 | 1.00 | R07 | 1.60 | | 312,570 |
| 300 | A | 0.695 | 11 | 1.00 | 1 | 1.00 | 1 | 1.00 | 44,000 | 1.00 | 1 | 1.00 | R07 | 1.60 | | 30,580 |

DETACHED

| TOTAL | 1.470 Acres | ZONING | RES | FRNT | 0 | ASSESSED | CURRENT | PREVIOUS |
|--------------|-------------|--------|---------------|---------|---------|--------------|------------------|----------------|
| Nbhd | NORTH TRURO | NOTE | | | | LAND | 343,200 | 298,400 |
| Inf1 | 70% | | LAND BUILDING | 656,900 | 536,600 | | | |
| Inf2 | NO ADJ | | DETACHED | 200 | 100 | | | |
| | | | | | | OTHER | 0 | 0 |
| TOTAL | | | | | | TOTAL | 1,000,300 | 835,100 |

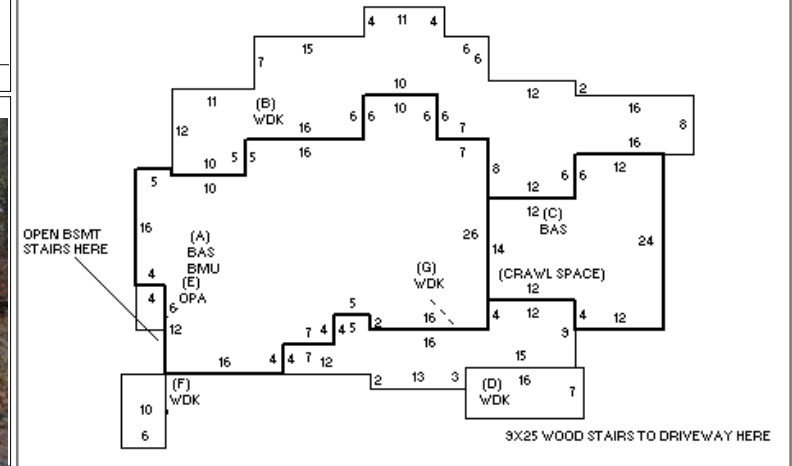

BUILDING

| TY | QUAL | COND | DIM/NOTE | YB | UNITS | ADJ PRICE | RCNLD |
|-----|------|------|------------|------|-------|-----------|-------|
| SHF | A | 1.00 | A 0.75 3*4 | 1979 | 12 | 17.17 | 200 |

| BLDG COMMENTS |
|--|
| 11/4/2020 CYC List w/owner via phone (C-19). |

| BUILDING | CD | ADJ | DESC | MEASURE | 1/16/2020 | LG |
|----------|----|------|-------------------|---------|-----------|----|
| MODEL | 1 | | RESIDENTIAL | LIST | 11/4/2020 | LG |
| STYLE | 1 | 1.00 | RANCH [100%] | REVIEW | 5/15/2002 | JC |
| QUALITY | G | 1.35 | GOOD [100%] | | | |
| FRAME | 1 | 1.00 | WOOD FRAME [100%] | | | |

| YEAR BLT | 1979 | SIZE ADJ | 1.010 | ELEMENT | CD | DESCRIPTION | ADJ | S | BAT | T | DESCRIPTION | UNITS | YB | ADJ PRICE | RCN |
|------------|-------|------------|-------|-----------------|----|-----------------|------|---|-----|---|-----------------|-------|------|-----------|---------|
| NET AREA | 1,770 | DETAIL ADJ | 1.000 | FOUNDATION | 4 | BSMT WALL | 1.00 | A | BMU | N | BSMT UNFINISHED | 1,314 | | 90.54 | 118,972 |
| \$NLA(RCN) | \$538 | OVERALL | 1.000 | EXT. COVER | 1 | WOOD SHINGLES | 1.00 | + | WDK | N | ATT WOOD DECK | 1,346 | | 61.46 | 82,725 |
| | | | | ROOF SHAPE | 7 | OTHER | 1.00 | + | BAS | L | BAS AREA | 1,770 | 1979 | 399.96 | 707,928 |
| | | | | ROOF COVER | 1 | ASPHALT SHINGLE | 1.00 | E | OPA | N | OPEN PORCH | 24 | | 191.46 | 4,595 |
| | | | | FLOOR COVER | 1 | HARDWOOD | 1.00 | | F11 | O | FPL 1S 1OP | 2 | | 14,770.80 | 29,542 |
| | | | | INT. FINISH | 2 | DRYWALL | 1.00 | | MST | O | MASONRY STACK | 1 | | 4,102.80 | 4,103 |
| | | | | HEATING/COOLING | 1 | FORCED AIR | 1.00 | | | | | | | | |
| | | | | FUEL SOURCE | 2 | GAS | 1.00 | | | | | | | | |

| TOTAL RCN | 952,064 |
|----------------|------------|
| CONDITION ELEM | CD |
| EFF.YR/AGE | 1983 / 39 |
| COND | 31 31 % |
| FUNC | 0 |
| ECON | 0 |
| DEPR | 31 % GD 69 |
| RCNLD | \$656,900 |