

Key: 1682

Town of TRURO - Fiscal Year 2024

9/27/2023 7:11 pm SEQ #: 1.691

LEGAL

| CURRENT OWNER | | | | PARCEL ID | | | | LOCATION | | | |
|--|--|--|--|------------|----|------------|--------------|---------------|--|--|--|
| RINKEWICH ROBERT (LE) RMNDR: KING LESLIE ANN&DOUGLAS PO BOX 506 NO TRURO, MA 02652-0506 | | | | 42-111-0 | | | | 7 BAYBERRY RD | | | |
| TRANSFER HISTORY | | | | DOS | T | SALE PRICE | BK-PG (Cert) | | | | |
| RINKEWICH ROBERT (LE) | | | | 11/05/2013 | H | | (201942) | | | | |
| KING JANET P | | | | 10/21/1981 | 99 | 22,000 | (87153) | | | | |

| CLASS | CLASS% | DESCRIPTION | | | BN ID | BN | CARD | |
|--------|------------|---------------|------------|--------|------------|----|--------|-----|
| 1010 | 100 | SINGLE FAMILY | | | | 1 | 1 of 1 | |
| PMT NO | PMT DT | TY | DESC | AMOUNT | INSP | BY | 1st | % |
| FY2018 | | 35 | RES EXEMPT | | 02/12/2018 | | | 0 |
| 09-132 | 07/28/2009 | 10 | ALL OTHERS | 19,500 | 05/19/2010 | JH | 100 | 100 |
| 89-56 | 04/01/1989 | 7 | GARAGE | 8,000 | 06/07/1993 | | 100 | 100 |

LAND

| CD | T | AC/SF/UN | Nbhd | Inf1 | Inf2 | ADJ BASE | SAF | Inf3 | Lpi | VC | CREDIT AMT | ADJ VALUE |
|-----|---|----------|------|------|------|----------|-----|------|-----|------|------------|-----------|
| 100 | A | 0.720 | 11 | 1.00 | 1 | 1.00 | 1 | 1.00 | R07 | 1.60 | | 436,490 |

| | | | | | | | | |
|-------|-------------|--------|---|---------|---------|----------|---------|----------|
| TOTAL | 31,363 SF | ZONING | RES | FRNT | 0 | ASSESSED | CURRENT | PREVIOUS |
| Nbhd | NORTH TRURO | NOTE | FY09 NBHD CHNGD FROM 7 TO 6 PER REVIEW. | | | LAND | 436,500 | 379,500 |
| Inf1 | NO ADJ | | BUILDING | 371,300 | 315,200 | | | |
| Inf2 | NO ADJ | | DETACHED | 22,000 | 21,000 | | | |
| | | | OTHER | 0 | 0 | | | |
| | | | TOTAL | 829,800 | 715,700 | | | |

DETAILED

| TY | QUAL | COND | DIM/NOTE | YB | UNITS | ADJ PRICE | RCNLD |
|-----|------|------|--------------|------|-------|-----------|--------|
| GUL | A | 1.00 | A 0.75 24*26 | 1988 | 624 | 47.10 | 22,000 |

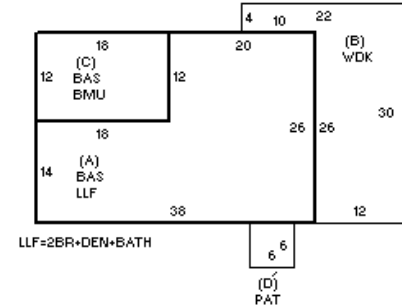

BUILDING

| BUILDING | CD | ADJ | DESC | MEASURE | 5/8/2018 | LG |
|----------|----|------|-------------------|---------|------------|----|
| MODEL | 1 | | RESIDENTIAL | LIST | 5/11/2018 | LG |
| STYLE | 1 | 1.00 | RANCH [100%] | REVIEW | 11/22/2010 | MR |
| QUALITY | A | 1.00 | AVERAGE [100%] | | | |
| FRAME | 1 | 1.00 | WOOD FRAME [100%] | | | |

BLDG COMMENTS

ODS on GUL

BUILDING

| YEAR BLT | 1983 | SIZE ADJ | 1.010 | ELEMENT | CD | DESCRIPTION | ADJ | S | BAT | T | DESCRIPTION | UNITS | YB | ADJ PRICE | RCN | TOTAL RCN | 538,112 |
|------------|-------|------------|-------|-----------------|----|-----------------|------|---|-----|---|-----------------|-------|------|-----------|---------|-----------|---------|
| NET AREA | 1,760 | DETAIL ADJ | 1.000 | FOUNDATION | | | 1.00 | A | LLF | L | LOWER LEVEL FIN | 772 | 1983 | 214.56 | 165,638 | | |
| \$NLA(RCN) | \$306 | OVERALL | 1.040 | EXT. COVER | 10 | VERT. BOARD | 1.00 | + | BAS | L | BAS AREA | 988 | 1983 | 319.07 | 315,237 | | |
| | | | | ROOF SHAPE | 1 | GABLE | 1.00 | B | WDK | N | ATT WOOD DECK | 400 | | 53.66 | 21,464 | | |
| | | | | ROOF COVER | 1 | ASPHALT SHINGLE | 1.00 | C | BMU | N | BSMT UNFINISHED | 216 | | 85.81 | 18,534 | | |
| | | | | FLOOR COVER | 1 | HARDWOOD | 1.00 | D | PAT | N | PATIO | 36 | | 26.67 | 960 | | |
| | | | | INT. FINISH | 2 | DRYWALL | 1.00 | | F11 | O | FPL 1S 10P | 1 | | 11,379.00 | 11,379 | | |
| | | | | HEATING/COOLING | 8 | HEAT PUMP | 1.04 | | | | | | | | | | |
| | | | | FUEL SOURCE | 3 | ELECTRIC | 1.00 | | | | | | | | | | |

| | |
|------------|------------|
| EFF.YR/AGE | 1983 / 39 |
| COND | 31 31 % |
| FUNC | 0 |
| ECON | 0 |
| DEPR | 31 % GD 69 |
| RCNLD | \$371,300 |