

Key: 1687

Town of TRURO - Fiscal Year 2024

9/27/2023 7:11 pm SEQ #: 1.696

LEGALS

CURRENT OWNER				PARCEL ID				LOCATION				
LEAVY JANE E 5803 CHEVY CHASE PKWY NW WASHINGTON, DC 20015-2523				42-117-0				8 HEATHER LN				
TRANSFER HISTORY				DOS	T	SALE PRICE	BK-PG (Cert)					
LEAVY JANE E				07/13/2011	99	(194724+)						
ISAKOFF PETER D & LEAVY J				11/03/2006	QS	1,550,000	(181524+)					
SCHWARTZ ROSELYN (LE) &				04/05/2004	99	(172579)						
CD	T	AC/SF/UN	Nbhd	Inf1	Inf2	ADJ BASE	SAF	Inf3	Lpi	VC	CREDIT AMT	ADJ VALUE
100	A	0.775	11	1.00	1	1,692,470	1.00	1	1.00	V17	4.70	1,311,660
300	A	0.285	11	1.00	1	129,250	1.00	1	1.00	V17	4.70	36,840

CLASS	CLASS%	DESCRIPTION			BN ID	BN	CARD	
1010	100	SINGLE FAMILY				1	1 of 1	
PMT NO	PMT DT	TY	DESC	AMOUNT	INSP	BY	1st	%
19-165X	05/29/2019	4	REHAB	40,000	08/27/2019	LG	100	100
16-013	01/15/2016	10	ALL OTHERS	40,000	12/21/2016		100	100
15-252	10/16/2015	90	BP NVC				100	100
15-095	05/01/2015	10	ALL OTHERS	15,408	09/21/2015	FC	100	100
13-090	04/23/2013	9	DECK	14,000	08/06/2013	FC	100	100

LAND

TOTAL	1.060 Acres	ZONING	RES	FRNT	0	ASSESSED	CURRENT	PREVIOUS
Nbhd	NORTH TRURO	N O T E	SPECTACULAR PANORAMIC VIEW.			LAND	1,348,500	1,172,500
Inf1	NO ADJ		BUILDING	851,800	695,900			
Inf2	NO ADJ		DETACHED	0	0			
			OTHER	0	0			
			TOTAL	2,200,300	1,868,400			

DETACHED

TY	QUAL	COND	DIM/NOTE	YB	UNITS	ADJ PRICE	RCNLD

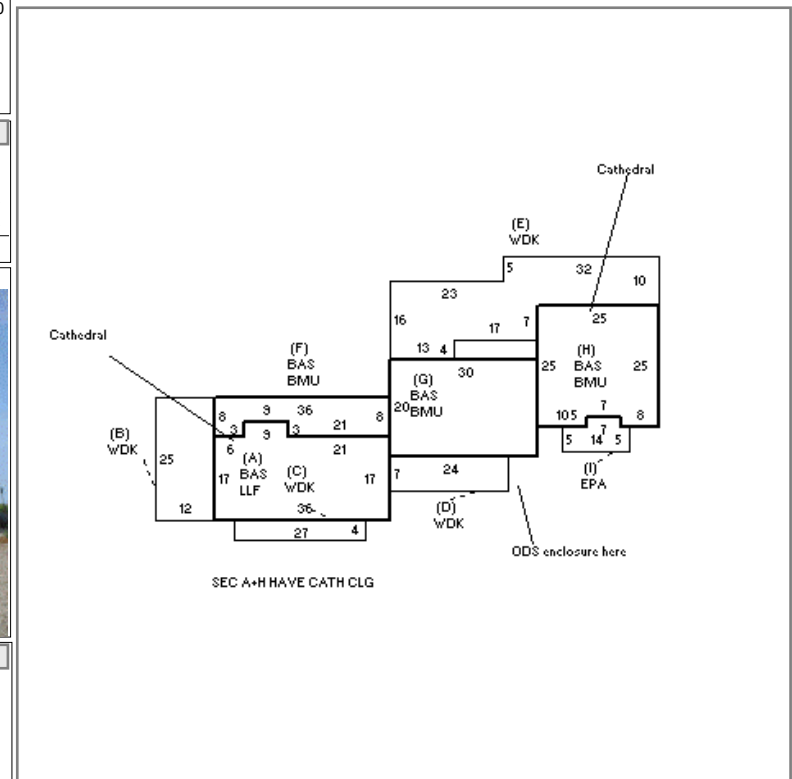

BUILDING

BUILDING	CD	ADJ	DESC	MEASURE	6/8/2021	LG
MODEL	1		RESIDENTIAL	LIST	9/21/2015	FC
STYLE	1	1.00	RANCH [100%]	REVIEW	5/25/2011	MR
QUALITY	G	1.35	GOOD [100%]			
FRAME	1	1.00	WOOD FRAME [100%]			

BLDG COMMENTS

LOADING

YEAR BLT	1971	SIZE ADJ	0.985	ELEMENT	CD	DESCRIPTION	ADJ	S	BAT	T	DESCRIPTION	UNITS	YB	ADJ PRICE	RCN	TOTAL RCN	1,216,789		
NET AREA	2,750	DETAIL ADJ	1.015	FOUNDATION	4	BSMT WALL	1.00	A	LLF	L	LOWER LEVEL FIN	639	1971	271.62	173,563	CONDITION ELEM	CD		
\$NLA(RCN)	\$442	OVERALL	1.000	EXT. COVER	1	WOOD SHINGLES	1.00	+	BAS	L	BAS AREA	1,511	1971	380.16	574,421				
				ROOF SHAPE	1	GABLE	1.00	+	WDK	N	ATT WOOD DECK	1,273		59.94	76,301				
				ROOF COVER	1	ASPHALT SHINGLE	1.00	+	BMU	N	BSMT UNFINISHED	1,472		85.52	125,886				
				FLOOR COVER	1	HARDWOOD	1.00	G	BAS	L	BAS AREA	600	1971	380.16	228,096				
				INT. FINISH	2	DRYWALL	1.00	I	EPA	N	ENCL PORCH	84		212.10	17,816				
				HEATING/COOLING	1	FORCED AIR	1.00	F11	O	FPL 1S 1OP	1		14,405.20	14,405					
				FUEL SOURCE	1	OIL	1.00	ODS	O	OUT DOOR SHOWER	1		0.00						
																		EFF.YR/AGE	1991 / 31
																		COND	30 30 %
																		FUNC	0
																		ECON	0
																		DEPR	30 % GD 70
																		RCNLD	\$851,800