

Key: 1689

Town of TRURO - Fiscal Year 2024

9/27/2023 7:11 pm SEQ #: 1.698

LEGALS

CURRENT OWNER		PARCEL ID		LOCATION	
CRISTIANO RONNIE L&FRANK A -LE RMNDR: CRISTIANO FAM TRURO TR 16 WEST VIEW LANE STOW, MA 01775		42-119-0		30 BAYBERRY RD	
TRANSFER HISTORY		DOS	T	SALE PRICE	BK-PG (Cert)
CRISTIANO RONNIE L&FRANK		12/31/2009	99		(190445)
CRISTIANO RONNIE L & FRAN		10/13/2000	QS	552,000	(159385)
GOODRICH JOHN C & YOUNG L		08/29/1995	QS	207,500	(138128)

CLASS	CLASS%	DESCRIPTION		BN ID	BN	CARD	
1010	100	SINGLE FAMILY			1	1 of 1	
PMT NO	PMT DT	TY	DESC	AMOUNT	INSP	BY	1st %
18-111	04/05/2018	80	SOLAR TAXABL	13,950	08/24/2018	LG	100 100
13-285	11/06/2013	2	ADDITION	232,000	12/04/2014	FC	100 100
95-088	07/05/1995	2	ADDITION	40,000	06/01/1997		100 100

LAND

CD	T	AC/SF/UN	Nbhd	Inf1	Inf2	ADJ BASE	SAF	Inf3	Lpi	VC	CREDIT AMT	ADJ VALUE
100	A	0.775	11	1.00	1	630,175	1.00	1	1.00	V7	1.75	488,390
300	A	0.285	11	1.00	1	48,125	1.00	1	1.00	V7	1.75	13,720

DETACHED

TOTAL	1.060 Acres	ZONING	RES	FRNT	0	ASSESSED	CURRENT	PREVIOUS
Nbhd	NORTH TRURO	NOTE NO VIEW FROM 1ST FLR PER 12/30/13 MEAS.				LAND	502,100	436,600
Inf1	NO ADJ		BUILDING	612,800	497,800			
Inf2	NO ADJ		DETACHED	0	0			
					OTHER	0	0	
TOTAL						1,114,900	934,400	

TY	QUAL	COND	DIM/NOTE	YB	UNITS	ADJ PRICE	RCNLD

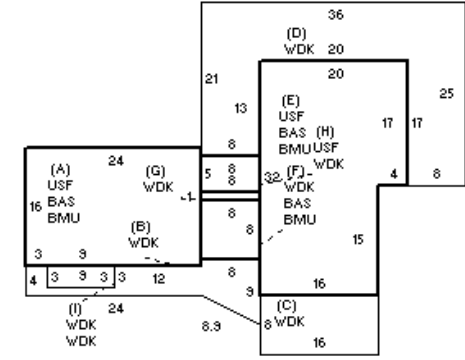

BUILDING

BUILDING	CD	ADJ	DESC	MEASURE	8/24/2018	LG
MODEL	1		RESIDENTIAL	LIST	9/6/2018	LG
STYLE	8	1.10	CONTEMPORARY [100%]	REVIEW	11/22/2010	MR
QUALITY	+	1.15	GOOD-AVE+ [100%]			
FRAME	1	1.00	WOOD FRAME [100%]			

BLDG COMMENTS

INDING

YEAR BLT	1984	SIZE ADJ	1.000	ELEMENT	CD	DESCRIPTION	ADJ	S	BAT	T	DESCRIPTION	UNITS	YB	ADJ PRICE	RCN	TOTAL RCN	875,415
NET AREA	2,032	DETAIL ADJ	1.000	FOUNDATION	4	BSMT WALL	1.00	+	BMU	N	BSMT UNFINISHED	1,028		88.87	91,360		
\$NLA(RCN)	\$431	OVERALL	1.120	EXT. COVER	10	VERT. BOARD	1.00	+	BAS	L	BAS AREA	1,028	1984	391.24	402,192		
				ROOF SHAPE	4	FLAT/SHED	1.00	+	USF	L	UP-STRY FIN	424	2013	298.61	126,610		
				ROOF COVER	7	ROLL	1.00	+	WDK	N	ATT WOOD DECK	947		58.06	54,980		
				FLOOR COVER	3	W/W CARPET	1.00	E	USF	L	UP-STRY FIN	580	1984	298.61	173,194		
				INT. FINISH	2	DRYWALL	1.00		F21	O	FPL 2S 1OP	1		19,379.20	19,379		
				HEATING/COOLING	2	HOT WATER	1.02		ODS	O	OUT DOOR SHOWER			0.00			
				FUEL SOURCE	1	OIL	1.00										

CONDITION ELEM	CD

EFF.YR/AGE	1990 / 32
COND	30 30 %
FUNC	0
ECON	0
DEPR	30 % GD 70
RCNLD	\$612,800