

Key: 1693

Town of TRURO - Fiscal Year 2024

9/27/2023 7:11 pm SEQ #: 1.702

LEGAL

LAND

DETACHED

BUILDING

CURRENT OWNER				PARCEL ID				LOCATION			
ROBERTS DAVID J & KATHLEEN 20 OXBOW RD WELLESLEY, MA 02481				42-123-0				22 BAYBERRY RD			
TRANSFER HISTORY				DOS	T	SALE PRICE	BK-PG (Cert)				
ROBERTS DAVID J & KATHLEE				02/14/1989	QS	285,000	(116830)				

CLASS	CLASS%	DESCRIPTION			BN ID	BN	CARD	
1010	100	SINGLE FAMILY				1	1 of 1	
PMT NO	PMT DT	TY	DESC	AMOUNT	INSP	BY	1st	%
19-263X	09/03/2019	90	BP NVC	2,700	11/19/2019	LG	100	100
10-264	12/23/2010	90	BP NVC	30,000	02/22/2012	FC	100	100
		20	NO PERMIT		10/05/2009	JH	100	100
04-229	12/21/2004	3	REPAIR/REMOD	50,000	06/12/2006	WL	100	100
02-011	01/30/2002	3	REPAIR/REMOD	68,000			100	100

CD	T	AC/SF/UN	Nbhd	Infl1	Infl2	ADJ BASE	SAF	Infl3	Lpi	VC	CREDIT AMT	ADJ VALUE
100	A	0.560	11	1.00	1	1.00	1	1.00	R07	1.60		403,960

TOTAL	24,394 SF	ZONING	RES	FRNT	0	ASSESSED	CURRENT	PREVIOUS
Nbhd	NORTH TRURO	N	FY19 Chnged view to Minimal. FY07=ADDED VW (FROM ROOF DECK ONLY). FY09 NBHD CHNGD FROM 7 TO 6 PER REVIEW.			LAND	404,000	351,200
Infl1	NO ADJ	O				BUILDING	1,317,000	1,089,800
Infl2	NO ADJ	T				DETACHED	0	0
		E				OTHER	0	0
						TOTAL	1,721,000	1,441,000

TY	QUAL	COND	DIM/NOTE	YB	UNITS	ADJ PRICE	RCNLD



BLDG COMMENTS  
1 BR OVER AGR.

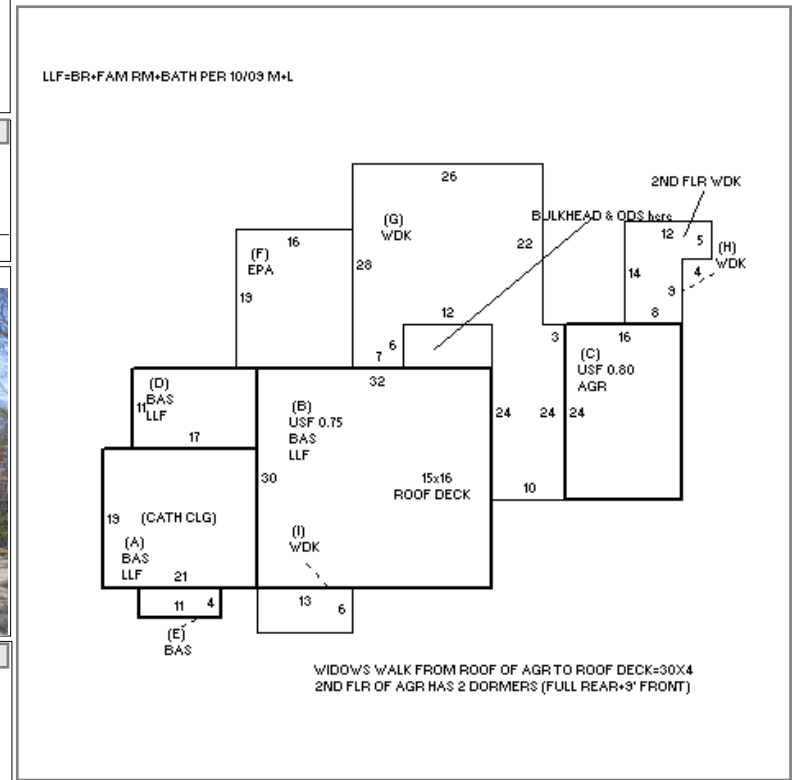

BUILDING	CD	ADJ	DESC	MEASURE	5/8/2018	LG
MODEL	1		RESIDENTIAL	LIST	10/5/2009	JH
STYLE	4	1.10	CAPE [100%]	REVIEW	11/22/2010	MR
QUALITY	G	1.35	GOOD [100%]			
FRAME	1	1.00	WOOD FRAME [100%]			

YEAR BLT	1987	SIZE ADJ	0.970
NET AREA	4,163	DETAIL ADJ	1.000
\$NLA(RCN)	\$416	OVERALL	1.120
CAPACITY		UNITS	ADJ
STORIES(FAR)		1.75	1.00
ROOMS		8	1.00
BEDROOMS		4	1.00
BATHROOMS		3	1.00
FIXTURES		9	\$6,300
UNITS		0	1.00

ELEMENT	CD	DESCRIPTION	ADJ	S	BAT	T	DESCRIPTION	UNITS	YB	ADJ PRICE	RCN
FOUNDATION	4	BSMT WALL	1.00	+	LLF	L	LOWER LEVEL FIN	1,546	1987	282.62	436,933
EXT. COVER	2	CLAPBOARD	1.00	A	BAS	L	BAS AREA	399	1987	436.76	174,269
ROOF SHAPE	6	SALTBOX	1.00	+	USF	L	UP-STRY FIN	1,027	1987	340.03	349,207
ROOF COVER	1	ASPHALT SHINGLE	1.00	C	AGR	N	ATTACHED GARAGE	384		144.60	55,526
FLOOR COVER	1	HARDWOOD	1.00	+	BAS	L	BAS AREA	1,191	1987	436.77	520,188
INT. FINISH	2	DRYWALL	1.00	F	EPA	N	ENCL PORCH	304		172.91	52,584
HEATING/COOLING	2	HOT WATER	1.02	+	WDK	N	ATT WOOD DECK	1,064		66.11	70,340
FUEL SOURCE	1	OIL	1.00		WDK	N	ATT WOOD DECK	240		79.33	19,040
					WDK	N	ATT WOOD DECK	120		88.15	10,577
					F11	O	FPL 1S 1OP	1		15,888.10	15,888
					F21	O	FPL 2S 1OP	1		22,067.10	22,067
					ODS	O	OUT DOOR SHOWER			0.00	

TOTAL RCN	1,732,899
CONDITION ELEM	CD
EFF.YR/AGE	1998 / 24
COND	24 24 %
FUNC	0
ECON	0
DEPR	24 % GD 76
RCNLD	\$1,317,000