

Key: 1709

Town of TRURO - Fiscal Year 2024

9/27/2023 7:11 pm SEQ #: 1.719

LEGALS

CURRENT OWNER				PARCEL ID				LOCATION				
SWAIN JONAH L PO BOX 497 NO TRURO, MA 02652				42-139-0				12 HART RD				
TRANSFER HISTORY				DOS	T	SALE PRICE	BK-PG (Cert)					
SWAIN JONAH L				06/26/2009	99		23837-104					
J S L NOMINEE TR				01/08/1999	QS	90,000	11979-255					
MACDONALD REALTY TRUST				06/02/1998	F		11472-218					
CD	T	AC/SF/UN	Nbhd	Inf1	Inf2	ADJ BASE	SAF	Inf3	Lpi	VC	CREDIT AMT	ADJ VALUE
100	A	0.775	11	1.00	1	1.00	1	1.00	R08	1.75		488,390
300	A	0.285	11	1.00	1	1.00	1	1.00	R08	1.75		13,720

CLASS	CLASS%	DESCRIPTION			BN ID	BN	CARD	
1010	100	SINGLE FAMILY				1	1 of 2	
PMT NO	PMT DT	TY	DESC	AMOUNT	INSP	BY	1st	%
22-465	11/21/2022	1	SINGLE FAM R	200,000	12/15/2022	LG	0	0
FY2018		35	RES EXEMPT		10/01/2017		0	0
16-248	10/20/2016	99	ALL OTHER	42,590	01/23/2017	LG	100	100
16-056	04/01/2016	6	SHED	4,000	01/23/2017	LG	100	100
		30	CHECK DATA		11/19/2012	FC	100	100

LAND

TOTAL	1.060 Acres	ZONING	RES	FRNT	0	ASSESSED	CURRENT	PREVIOUS
Nbhd	NORTH TRURO	NOTE	LAND	502,100	436,600	BUILDING	978,700	803,300
Inf1	NO ADJ		DETACHED	4,300	4,200	OTHER	0	0
Inf2	NO ADJ		TOTAL	1,485,100	1,244,100			

DETACHED

TY	QUAL	COND	DIM/NOTE	YB	UNITS	ADJ PRICE	RCNLD
SHF	A	1.00	A 0.75 10*20	2016	200	15.54	2,300
HTB	A	1.00	A 0.75 8*8		1	2,730.40	2,000

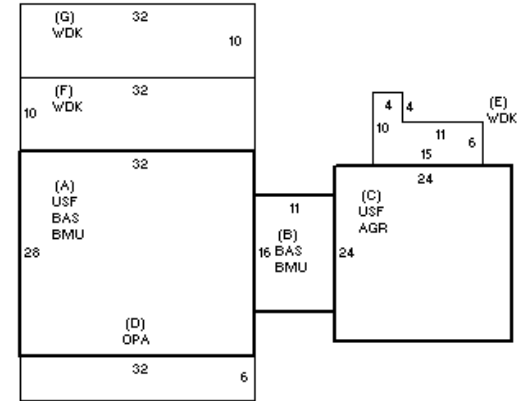

BUILDING

BUILDING	CD	ADJ	DESC	MEASURE	1/23/2017	LG
MODEL	1		RESIDENTIAL	LIST	5/20/2010	EST
STYLE	4	1.10	CAPE [100%]	REVIEW	3/5/2013	BE
QUALITY	+	1.15	GOOD-AVE+ [100%]			
FRAME	1	1.00	WOOD FRAME [100%]			

BLDG COMMENTS

BUILDING

YEAR BLT	2010	SIZE ADJ	0.990	ELEMENT	CD	DESCRIPTION	ADJ	S	BAT	T	DESCRIPTION	UNITS	YB	ADJ PRICE	RCN	TOTAL RCN	1,112,139
NET AREA	2,544	DETAIL ADJ	1.000	FOUNDATION	4	BSMT WALL	1.00	+	BMU	N	BSMT UNFINISHED	1,072		90.34	96,845	CONDITION ELEM	CD
\$NLA(RCN)	\$437	OVERALL	1.150	EXT. COVER	1	WOOD SHINGLES	1.00	+	BAS	L	BAS AREA	1,072	2010	397.70	426,334		
CAPACITY		UNITS	ADJ	ROOF SHAPE	1	GABLE	1.00	+	USF	L	UP-STRY FIN	1,472	2010	294.06	432,852		
STORIES(FAR)	2	1.00		ROOF COVER	1	ASPHALT SHINGLE	1.00	C	AGR	N	ATTACHED GARAGE	576		118.33	68,157		
ROOMS	6	1.00		FLOOR COVER	2	SOFTWOOD	1.00	D	OPA	N	OPEN PORCH	192		97.02	18,627		
BEDROOMS	3	1.00		INT. FINISH	2	DRYWALL	1.00	+	WDK	N	ATT WOOD DECK	746		59.02	44,026		
BATHROOMS	2.5	1.00		HEATING/COOLING	11	HOT WAT.-CL AIR	1.05	F21	O	FPL 2S 1OP	1		19,699.40	19,699			
FIXTURES	8	\$5,600		FUEL SOURCE	2	GAS	1.00	ODS	O	OUT DOOR SHOWER	1		0.00				
UNITS	0	1.00															
																EFF.YR/AGE	2010 / 12
																COND	12 12 %
																FUNC	0
																ECON	0
																DEPR	12 % GD 88
																RCNLD	\$978,700

Key: 1709

Town of TRURO - Fiscal Year 2024

9/27/2023 7:11 pm SEQ #: 1.720

LEGAL

CURRENT OWNER				PARCEL ID				LOCATION			
SWAIN JONAH L PO BOX 497 NO TRURO, MA 02652				42-139-0				12 HART RD			
TRANSFER HISTORY				DOS	T	SALE PRICE	BK-PG (Cert)				

CLASS	CLASS%	DESCRIPTION			BN ID	BN	CARD	
1010	100	SINGLE FAMILY				2	2 of 2	
PMT NO	PMT DT	TY	DESC	AMOUNT	INSP	BY	1st	%

LAND

CD	T	AC/SF/UN	Nbhd	Infl1	Infl2	ADJ BASE	SAF	Infl3	Lpi	VC	CREDIT AMT	ADJ VALUE
----	---	----------	------	-------	-------	----------	-----	-------	-----	----	------------	-----------

TOTAL	ZONING	FRNT	ASSESSED	CURRENT	PREVIOUS
Nbhd	NOTE		LAND	0	
Infl1		BUILDING			
Infl2		DETACHED			
		OTHER			
			TOTAL		

DETACHED

TY	QUAL	COND	DIM/NOTE	YB	UNITS	ADJ PRICE	RCNLD	PHOTO
								12/15/2022



BLDG COMMENTS

BUILDING

BUILDING	CD	ADJ	DESC	MEASURE
MODEL	1		RESIDENTIAL	LIST
STYLE	0	1.00	[100%]	REVIEW
QUALITY		1.00	[100%]	
FRAME		1.00	[100%]	

G

YEAR BLT	0	SIZE ADJ	1.000	ELEMENT	CD	DESCRIPTION	ADJ	S	BAT	T	DESCRIPTION	UNITS	YB	ADJ PRICE	RCN	TOTAL RCN	0
NET AREA	0	DETAIL ADJ	1.000	FOUNDATION	0		1.00									CONDITION ELEM	CD
\$NLA(RCN)	\$0	OVERALL	1.000	EXT. COVER	0		1.00										
CAPACITY		UNITS	ADJ	ROOF SHAPE	0		1.00										
STORIES(FAR)	0	1.00		ROOF COVER	0		1.00										
ROOMS	0	1.00		FLOOR COVER	0		1.00										
BEDROOMS	0	1.00		INT. FINISH	0		1.00										
BATHROOMS	0	1.00		HEATING/COOLING	0		1.00										
FIXTURES	0	1.00		FUEL SOURCE	0		1.00										
UNITS	0	1.00															
																EFF.YR/AGE	0 / 0
																COND	0 0 %
																FUNC	0
																ECON	0
																DEPR	0 % GD 100
																RCNLD	\$0