

Key: 1762

Town of TRURO - Fiscal Year 2024

9/27/2023 7:11 pm SEQ #: 1.775

LEGAL

CURRENT OWNER				PARCEL ID				LOCATION			
JAMES M KYED LIVING TRUST				42-180-0				2 GREAT HOLLOW LN			
TRS: JAMES M KYED				TRANSFER HISTORY				DOS T SALE PRICE BK-PG (Cert)			
PO BOX 7				JAMES M KYED LIVING TRUST				07/01/2020 F 10 33035-316			
NO TRURO, MA 02652				KYED JAMES M				06/11/1987 99 5770-127			

CLASS	CLASS%	DESCRIPTION			BN ID	BN	CARD	
1010	100	SINGLE FAMILY				1	1 of 1	
PMT NO	PMT DT	TY	DESC	AMOUNT	INSP	BY	1st	%
FY2018		35	RES EXEMPT		01/05/2018			0
91-019	03/29/1991	9	DECK	1,000	05/22/1991		100	100
88-069	05/09/1988	2	ADDITION	12,000	07/14/1988	SW	100	100

LAND

CD	T	AC/SF/UN	Nbhd	Infl1	Infl2	ADJ BASE	SAF	Infl3	Lpi	VC	CREDIT AMT	ADJ VALUE
100	A	0.730	11	1.00	1	1.00	1	1.00	R08	1.75		479,440

TOTAL	31,799 SF	ZONING	GR6	FRNT	0	ASSESSED	CURRENT	PREVIOUS
Nbhd	NORTH TRURO	NOTE	LAND	479,400	416,900			
Infl1	NO ADJ		BUILDING	210,200	181,400			
Infl2	NO ADJ		DETACHED	700	700			
			OTHER	0	0			
			TOTAL	690,300	599,000			

DETACHED

TY	QUAL	COND	DIM/NOTE	YB	UNITS	ADJ PRICE	RCNLD
SHF	A	G	6*8		48	17.17	700

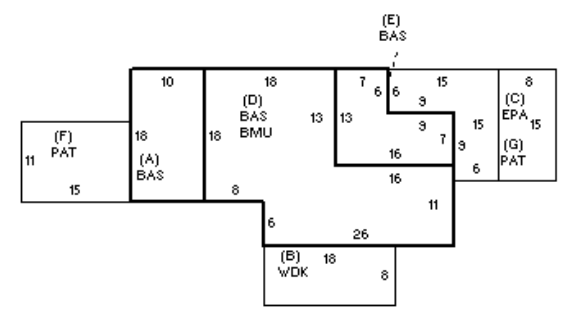

BUILDING

BUILDING	CD	ADJ	DESC	MEASURE	3/8/2018	LG
MODEL	1		RESIDENTIAL	LIST	3/8/2018	LG
STYLE	1	1.00	RANCH [100%]	REVIEW	11/22/2010	MR
QUALITY	A	1.00	AVERAGE [100%]			
FRAME	1	1.00	WOOD FRAME [100%]			

BLDG COMMENTS

INDING

YEAR BLT	1935	SIZE ADJ	1.050	ELEMENT	CD	DESCRIPTION	ADJ	S	BAT	T	DESCRIPTION	UNITS	YB	ADJ PRICE	RCN	TOTAL RCN	362,450
NET AREA	894	DETAIL ADJ	1.000	FOUNDATION			1.00	+	BAS	L	BAS AREA	894	1935	303.00	270,879	CONDITION ELEM	CD
\$NLA(RCN)	\$405	OVERALL	0.950	EXT. COVER	1	WOOD SHINGLES	1.00	B	WDK	N	ATT WOOD DECK	144		59.95	8,632		
CAPACITY				ROOF SHAPE	1	GABLE	1.00	C	EPA	N	ENCL PORCH	144		138.35	19,923		
STORIES(FAR)	1	1.00		ROOF COVER	1	ASPHALT SHINGLE	1.00	D	BMU	N	BSMT UNFINISHED	560		81.49	45,632		
ROOMS	5	1.00		FLOOR COVER	3	W/W CARPET	1.00	+	PAT	N	PATIO	285		15.71	4,478		
BEDROOMS	2	1.00		INT. FINISH	4	WALL BOARD	1.00	F11	O	O	FPL 1S 1OP	1		10,805.90	10,806		
BATHROOMS	1	1.00		HEATING/COOLING	5	ELECTRIC	0.95										
FIXTURES	3	\$2,100		FUEL SOURCE	3	ELECTRIC	1.00										
UNITS	0	1.00															
EFF.YR/AGE 1970 / 52																	
COND 42 42 %																	
FUNC 0																	
ECON 0																	
DEPR 42 % GD 58																	
RCNLD \$210,200																	